



Taurus Single-sided inbuilt







Encompassing style and class.

VisionLINE premium European fireplaces and venting systems are designed to meet the unique requirements of the New Zealand market.

This VisionLINE Taurus single-faced inbuilt fireplace is distinguished by exceptional build quality and designed to be installed with the innovative insulated zero clearance case using the VisionLINE Air Flue System for optimum efficiency.

*ECAN NO: **CRC243464 - Inbuilt**

Key Features

-  High heat/long burn times
-  Landscape viewing window
-  Kiln brick linings
-  Insulated Zero Clearance installation
-  15 year firebox warranty
-  Flued with the VisionLine Air Flue System
-  Ideal for passive homes

Approved to National Environmental Standards (NES)

The Fireplace Ltd reserves the right to change all content contained herein and is subject to change without notice.

Product Specifications

(All dimensions in millimetres)

Firebox Models	Inbuilt
Emissions	1g/kg
Efficiency	65%
Fuel Source	Softwood
Weight	220kg

Product Dimensions

DESCRIPTION	Height	Width	Depth
Inbuilt	567	1042	441
IZC	795	1345	589

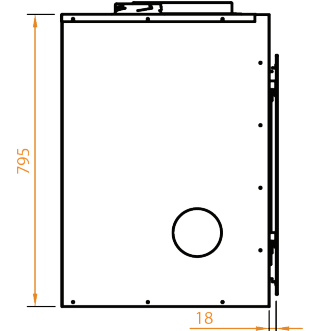
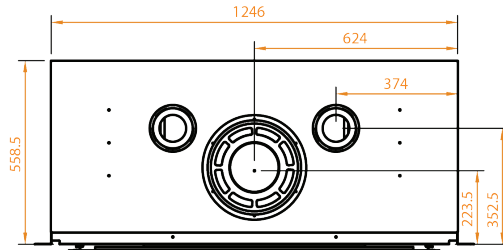
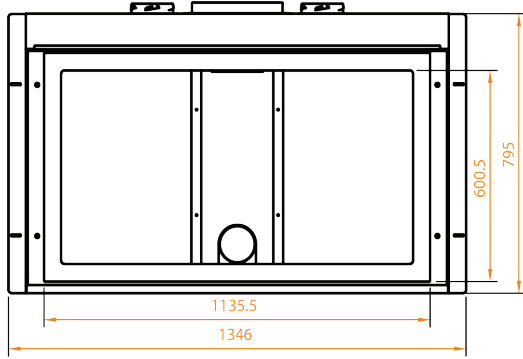

Installation Information

IMPORTANT: PLEASE REFER TO COMPREHENSIVE INSTALLATION INSTRUCTIONS PRIOR TO CONSTRUCTION AND INSTALLATION
 DOWNLOAD FROM: www.thefireplace.co.nz

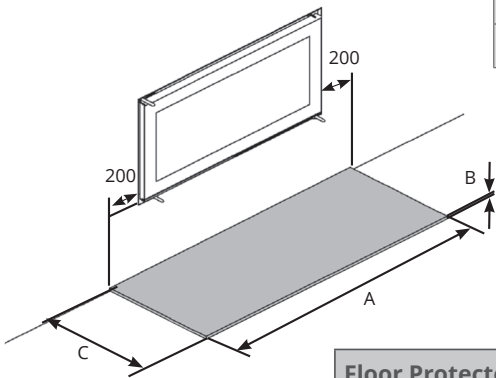

INBUILT CAVITY	A	B	C	D
Taurus	1295	590	323	1070

Floor Protector	A	B	C
Floor level or < 400mm	1230	42	600
Raised 400mm or >	1230	6	300

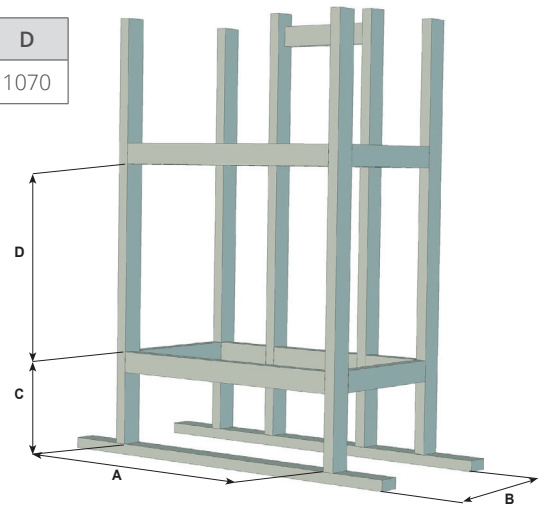

Options & Accessories

Vent Options

Forward Facing Vent (1200mm x 173.5mm)



Side Intake Vent x 2 (200mm x 100mm)

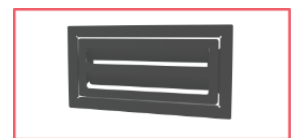
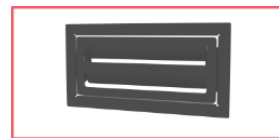

Side Facing Vent x 2 (422mm x 173mm)



Exclusive New Zealand Distributor

The Fireplace Ltd

12 Tawari Street, Mt Eden

Auckland 1024, New Zealand

Ph: 09 623 6990

Email: sales@thefireplace.co.nz

www.thefireplace.co.nz

Your Local Retailer