

Taurus | Single-sided

Freestanding installations



Taurus Single-sided Freestanding on steel bench

Encompassing style and class.

VisionLINE premium European fireplaces and venting systems are designed to meet the unique requirements of the New Zealand market.

This VisionLINE Taurus single-sided freestanding fireplace is distinguished by exceptional build quality and is available with a matching steel bench.

*ECAN NO: **CRC243463 - Freestanding**

Key Features

-  High heat/long burn times
-  Landscape viewing window
-  Kiln brick linings
-  Low emission wood burner
-  15 year firebox warranty
-  Optional sealed external air kit
-  Install with VisionLINE Flue System

Approved to National Environmental Standards (NES)

The Fireplace Ltd reserves the right to change all content contained herein and is subject to change without notice.

Product Specifications

(All dimensions in millimetres)

Firebox Models	Freestanding Single-sided
Emissions	1g/kg
Efficiency	65%
Fuel Source	Softwood
Weight	310kg including base

Product Dimensions

DESCRIPTION	Height	Width	Depth
Freestanding	567	1042	441
Bench	474	1042	441

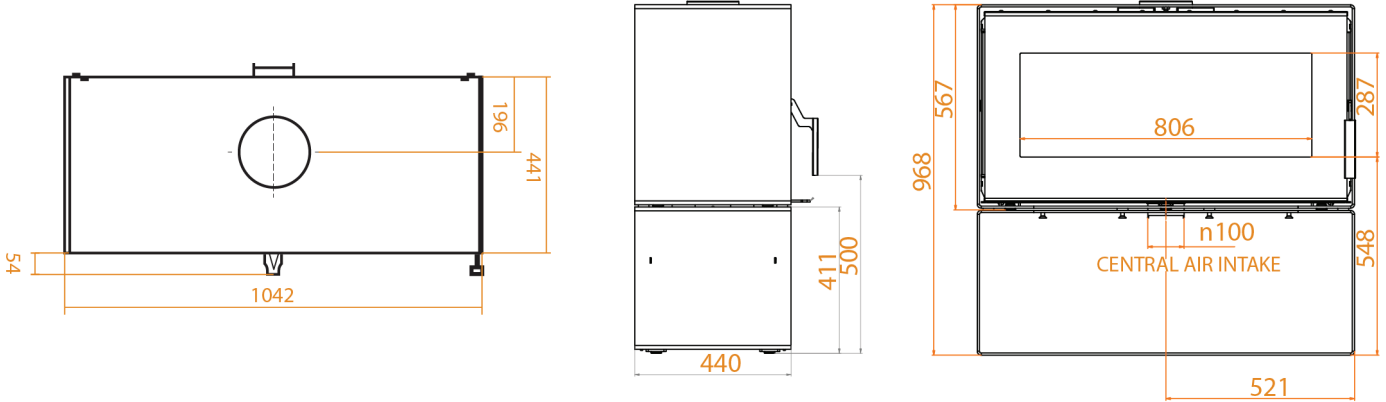

Installation Information

IMPORTANT: PLEASE REFER TO COMPREHENSIVE INSTALLATION INSTRUCTIONS PRIOR TO CONSTRUCTION AND INSTALLATION
 DOWNLOAD FROM: www.thefireplace.co.nz

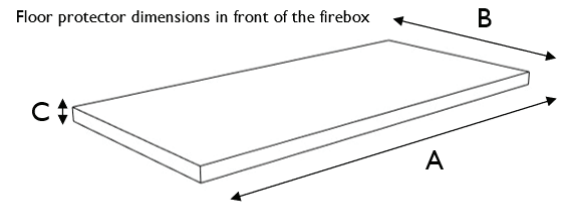
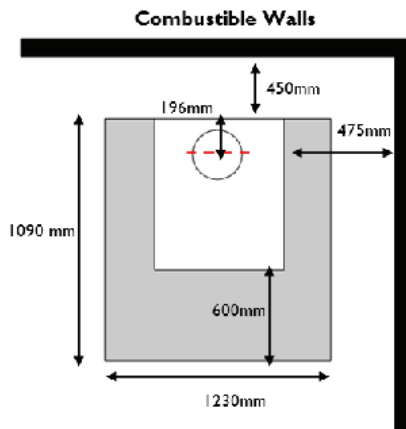
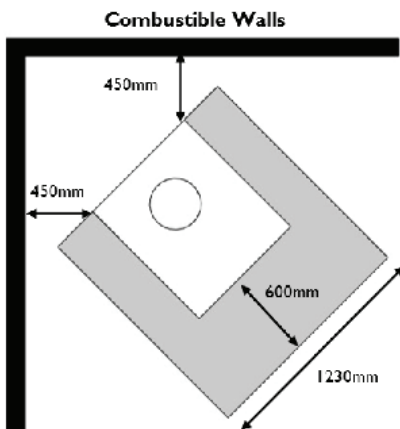

Floor Protector	A	B	C
Floor level or < 400mm	1230	600	42
Raised 400mm or >	1230	300	6

Options & Accessories

VisionLINE Air Flue System or Insulated Flue System

A co-axial, room sealed insulated flue system for freestanding solid fuel fires. Designed to increase the performance and efficiency in the home compared to a typical air cooled default flue. Ideal for passive homes.

VisionLINE Bench - Steel bench for freestanding installations

Outside Air Kit - Air for combustion

Heat Shield - Reduces the wall clearance from 450mm to 200mm from the back of the heat shield to the wall.



Exclusive New Zealand Distributor

The Fireplace Ltd

12 Tawari Street, Mt Eden

Auckland 1024, New Zealand

Ph: 09 623 6990

Email: sales@thefireplace.co.nz

www.thefireplace.co.nz

Your Local Retailer