



Taurus Double-sided Inbuilt

Encompassing style and class.

VisionLINE premium European fireplaces and venting systems are designed to meet the unique requirements of the New Zealand market.

This VisionLINE Taurus double-sided inbuilt fireplace is distinguished by exceptional build quality.

*ECAN NO: CRC243466 - Inbuilt

Key Features

-  High heat/long burn times
-  Landscape viewing window
-  Kiln brick linings
-  Low emission wood burner
-  15 year firebox warranty
-  Optional sealed external air kit
-  Zero clearance installation

Approved to National Environmental Standards (NES)

The Fireplace Ltd reserves the right to change all content contained herein and is subject to change without notice.

Product Specifications

(All dimensions in millimetres)

Firebox Models	Inbuilt Double-sided
Emissions	1g/kg
Efficiency	65%
Fuel Source	Softwood
Weight	220kg

Product Dimensions

DESCRIPTION	Height	Width	Depth
Inbuilt	567	1042	441
ZCB	790	1100	500
Steel Base	380	1100	500

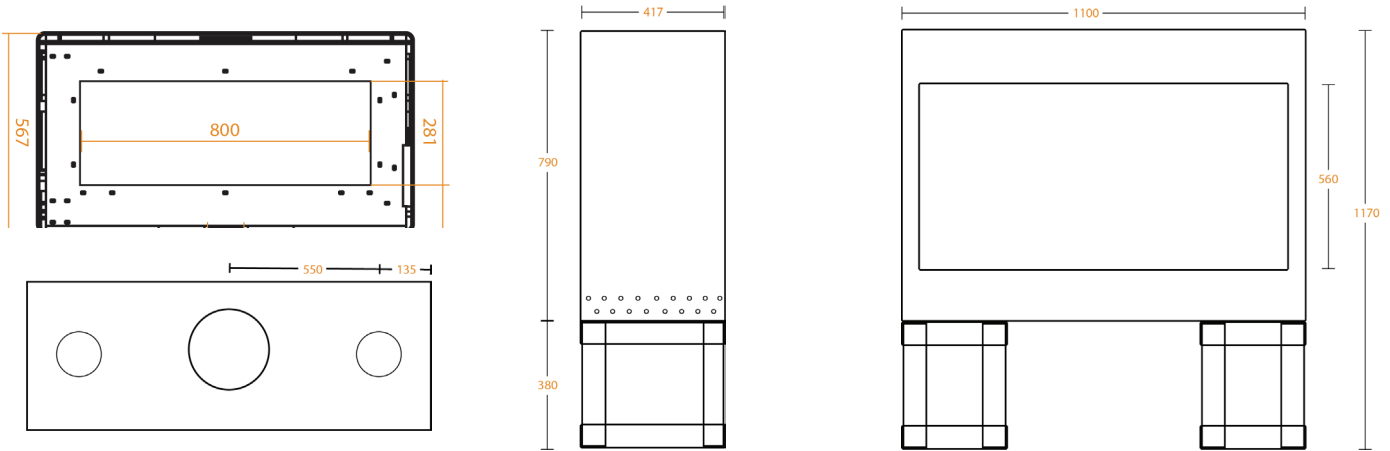

Installation Information

IMPORTANT: PLEASE REFER TO COMPREHENSIVE INSTALLATION INSTRUCTIONS PRIOR TO CONSTRUCTION AND INSTALLATION
 DOWNLOAD FROM: www.thefireplace.co.nz

INBUILT CAVITY	A	B*	C	D
Taurus	1300	420	400	1070

* outside to outside

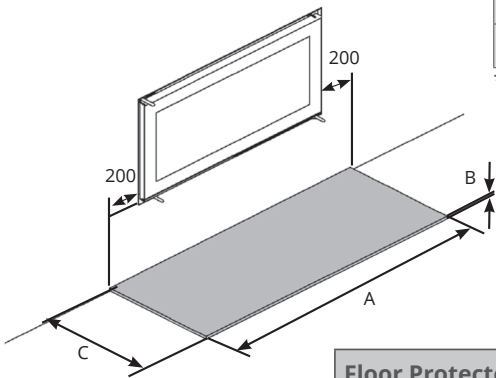

Floor Protector	A	B	C
Floor level or < 400mm	1230	42	600
Raised 400mm or >	1230	6	500

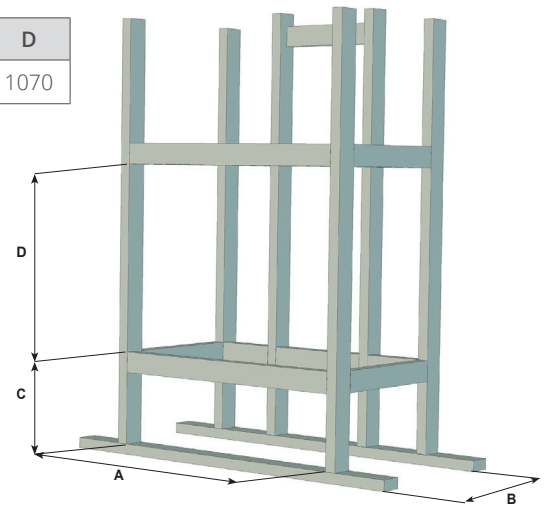

Options & Accessories

Inbuilt ZCB - Zero clearance box for timber frame installations.

Steel Base - Base for Zero clearance box to sit on.

Outside Air Kit - Air for combustion.

Steel Trim - Ideal for finishing around the firebox.



Exclusive New Zealand Distributor

The Fireplace Ltd

12 Tawari Street, Mt Eden

Auckland 1024, New Zealand

Ph: 09 623 6990

Email: sales@thefireplace.co.nz

www.thefireplace.co.nz

Your Local Retailer