



Taurus SF inbuilt







## Encompassing style and class.

VisionLINE premium European fireplaces and venting systems are designed to meet the unique requirements of the New Zealand market.

This VisionLINE Taurus single-faced fireplace is distinguished by exceptional build quality and is available as either a freestanding or an inbuilt appliance.

**\*ECAN NO: CRC243464 - Inbuilt  
CRC243463 - Freestanding**  
**Approved to National Environmental Standards (NES)**

## Key Features

-  High heat/long burn times
-  Landscape viewing window
-  Kiln brick linings
-  Low emission wood burner
-  15 year firebox warranty
-  Sealed external air kit
-  Zero Clearance (inbuilt) installation



## Product Specifications

(All dimensions in millimetres)

Firebox Models	Inbuilt & Freestanding SF
Emissions	1g/kg
Efficiency	65%
Fuel Source	Softwood
Weight	310kg including base

## Product Dimensions

DESCRIPTION	Height	Width	Depth
<b>Freestanding</b>	567	1042	441
<b>Inbuilt</b>	567	1042	441
<b>Bench</b>	474	1042	441

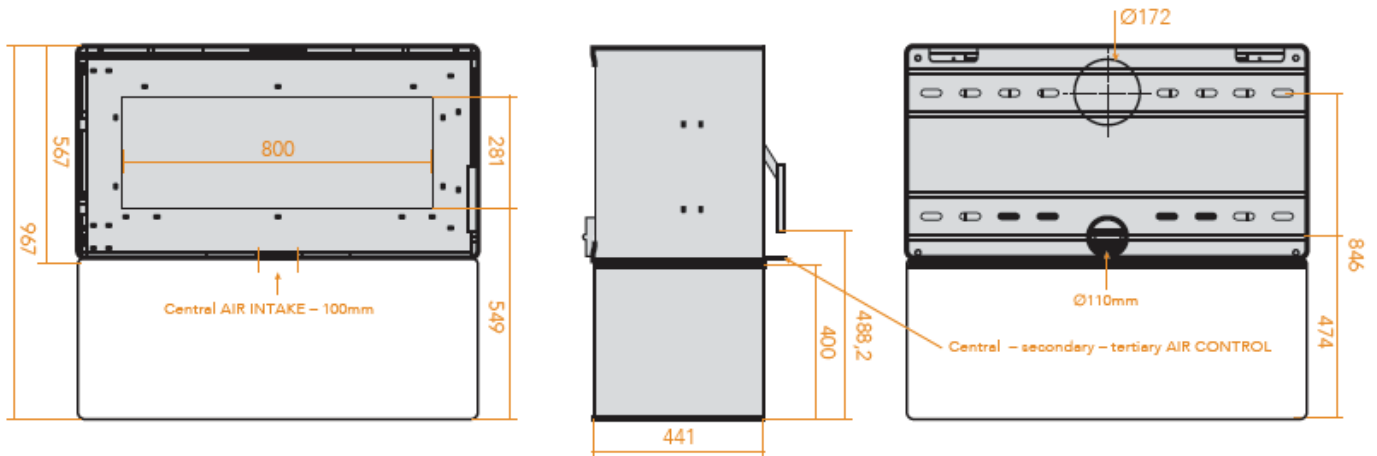

## Installation Information

IMPORTANT: PLEASE REFER TO COMPREHENSIVE INSTALLATION INSTRUCTIONS PRIOR TO CONSTRUCTION AND INSTALLATION  
 DOWNLOAD FROM: [www.thefireplace.co.nz](http://www.thefireplace.co.nz)

INBUILT CAVITY	A	B	C	D
<b>Taurus</b>	1300	550	400	1070

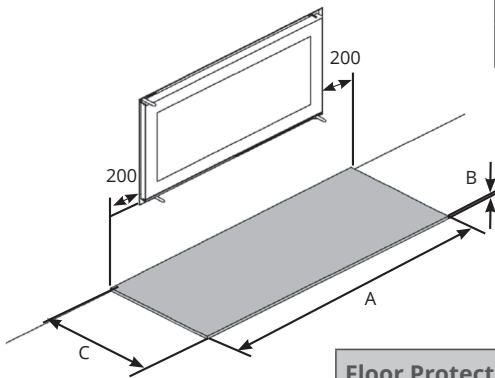

Floor Protector	A	B	C
<b>Foor level or &lt; 400mm</b>	1230	42	600
<b>Raised 400mm or &gt;</b>	1230	6	300

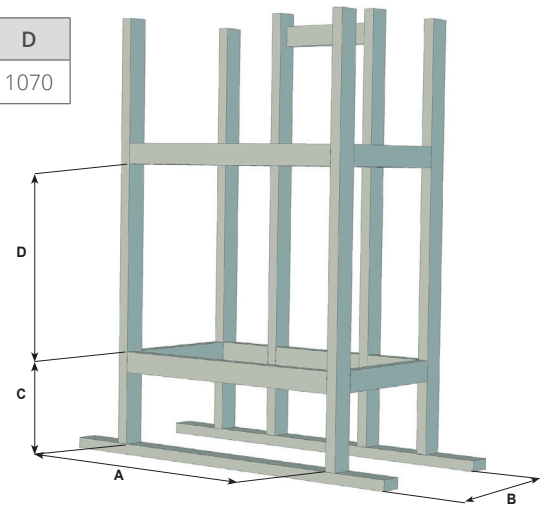

## Options & Accessories

### VisionLINE Air Flue System

A co-axial, room sealed insulated flue system for freestanding solid fuel fires. Designed to increase the performance and efficiency in the home when compared to a typical air cooled default flue. Ideal for passive homes.

### VisionLINE Freestanding Fire

**VisionLINE Bench** - Steel bench for freestanding installations

**Inbuilt ZCB** - Zero clearance box for timber frame installations.

**Outside Air Kit** - Air for combustion



Exclusive New Zealand Distributor

**The Fireplace Ltd**

12 Tawari Street, Mt Eden

Auckland 1024, New Zealand

Ph: 09 623 6990

Email: [sales@thefireplace.co.nz](mailto:sales@thefireplace.co.nz)

[www.thefireplace.co.nz](http://www.thefireplace.co.nz)

Your Local Retailer