



Stovax Studio 2 Clean-Air inbuilt fire with 25XS steel frame

Breathtaking design, clean air technology.





The Stovax Studio range balances presence with efficiency and heating performance. A selection from this peerless range of contemporary fires will add gravity and style to any interior. It represents the pinnacle of British fire design, engineering and technical innovation.

This Studio 2 Clean-Air inbuilt model has been specifically designed to meet stringent air quality standards. It is suitable for installation in most New Zealand airsheds.

***ECAN NO: CRC 133649**

Approved to National Environmental Standards (NES)

Key Features

-  Architecturally inspired design
-  Low emission wood burner*
-  High heat output fire
-  Landscape viewing window, with Airwash
-  Minimal ash and cleaning

Product Specifications

(All dimensions in millimetres)

Firebox Model #	RVST-2HTNZ
Average Heat Output	12kW
Emissions	1g/kg
Efficiency	66%
Fuel Source	Wood
Weight	190kg

Product Dimensions

Appliance	A	B	C	D	E	F	G
(mm)	1020	732	371	32	228	143	150

25XS Steel Facia	Width	Height	Depth
(mm)	1161	732	371

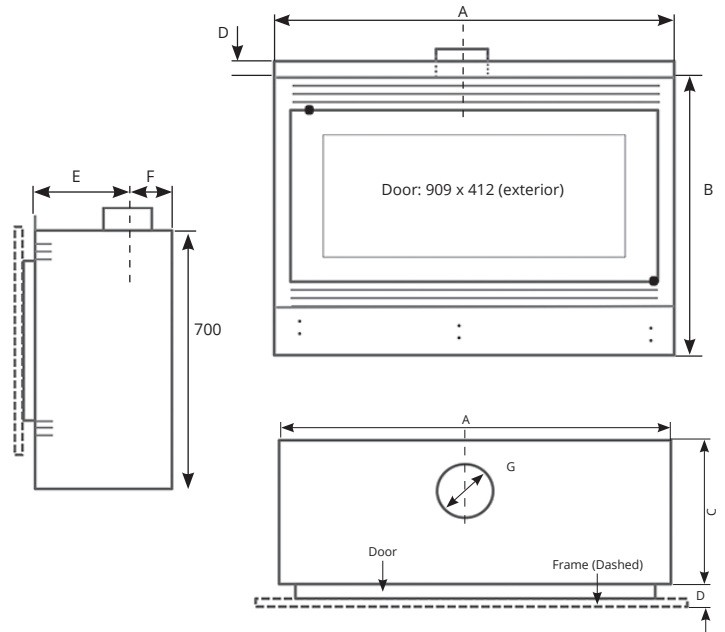

Installation Information

IMPORTANT: PLEASE REFER TO COMPREHENSIVE INSTALLATION INSTRUCTIONS PRIOR TO CONSTRUCTION AND INSTALLATION
 DOWNLOAD FROM: www.thefireplace.co.nz

Minimum Timber Frameout Dimensions

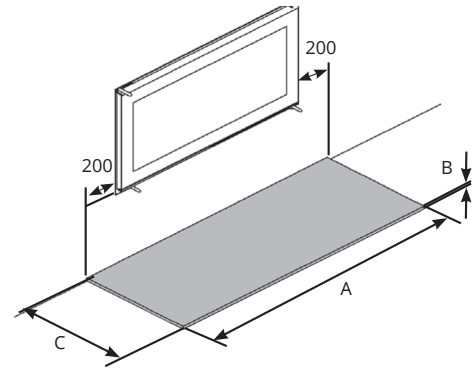
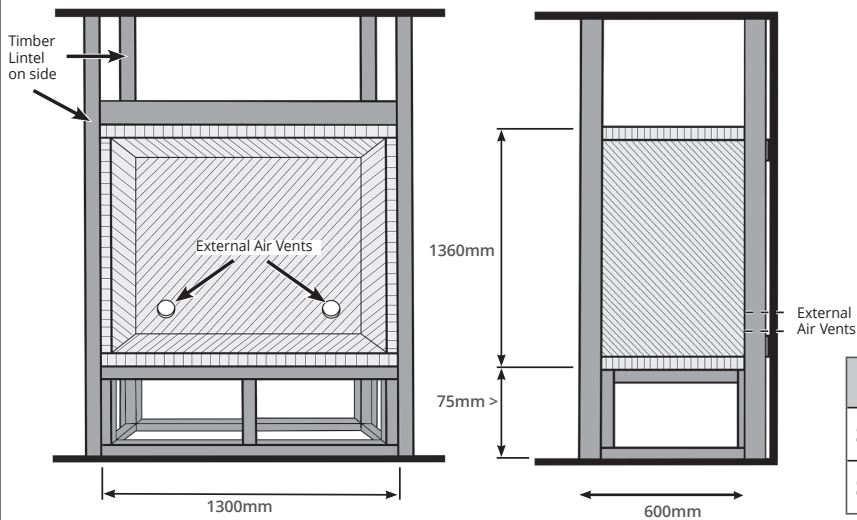

Floor Protector Minimum Dimensions

Floor Protector	A	B	C
Studio 2 floor level or < 300mm	1350	24	300
Studio 2 raised 300mm or >	1350	12	300

Options & Accessories

Steel Freestanding Cabinet (ZCB)
 1410w x 780h x 515d (mm)

Steel Bench
 1410w x 300h x 515d (mm)



Flue with Heat Shield



Exclusive New Zealand Distributor

The Fireplace Ltd

12 Tawari Street, Mt Eden
 Auckland 1024, New Zealand

Ph: 09 623 6990

Email: sales@thefireplace.co.nz

www.thefireplace.co.nz

Your Local Retailer