



PROUDLY
MADE IN CHRISTCHURCH
SINCE 1996



Devan Tanks are developed, designed and produced to the highest standards for New Zealand conditions.

WHY CHOOSE DEVAN?

Devan pioneered New Zealand's first large volume plastic water tank with the first development starting in the late 1980's.

Since then Devan has gone on to develop a full range of water tanks, septic tanks, wastewater systems and key accessories to assist with all your water based needs.

Devan Tanks are only manufactured from the highest quality polyethylene which is ideally suited to our moulding technique giving long life and trouble free service.

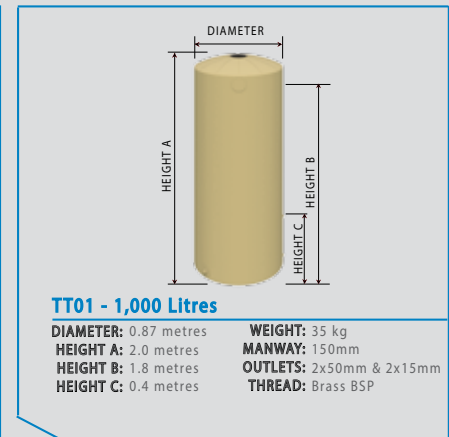
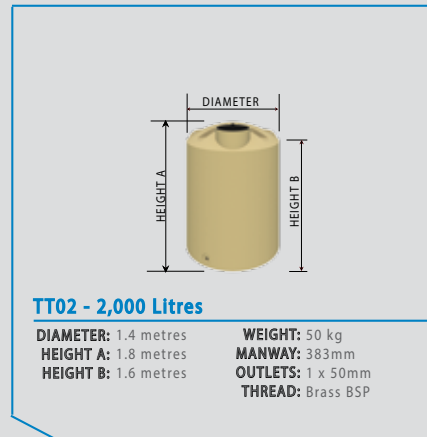
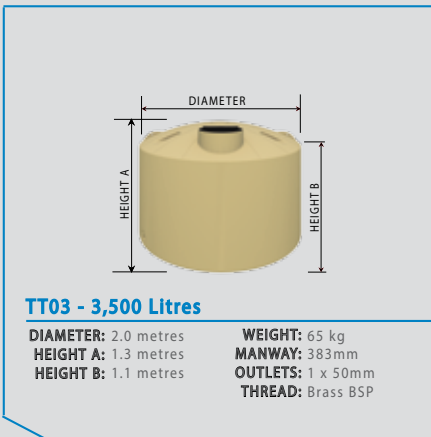
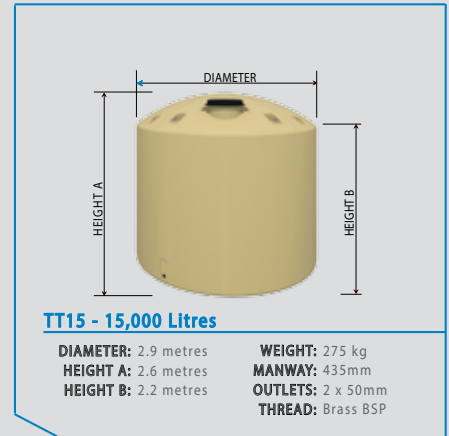
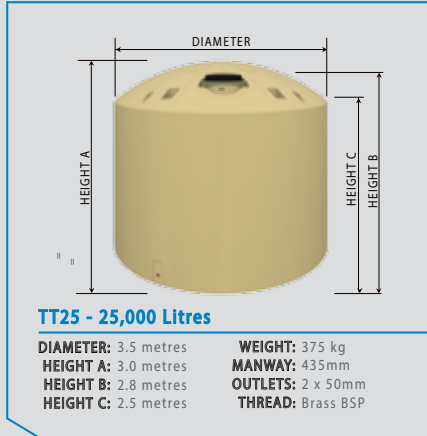
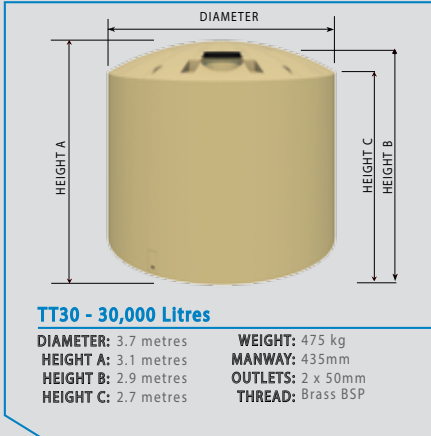

OUR 20 YEAR GUARANTEE

Devan Tanks offers a no nonsense 20 year guarantee on all our domestic water tanks. Our tanks are manufactured to the highest standards utilising advanced technology and production procedures. Full installation guides are available to ensure your installation meets the warranty conditions.



MOULDED OUTLETS

Devan Tanks are the only tank that comes with brass (or stainless steel) moulded in outlets. Having metal outlets allows for an easy plumb that is solid and eliminates any risk of cross threading. Better yet, our big tanks come with two of them as standard!

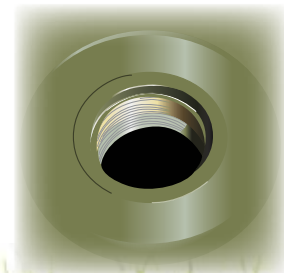

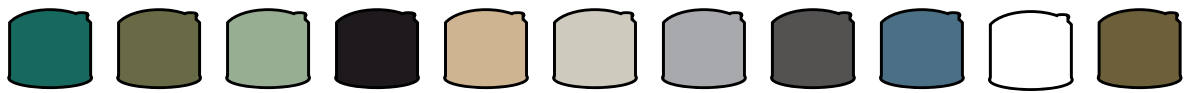

Devan Colours

Dark Green	Olive Green	Mist Green	Black	Beige	Birch Grey	Light Grey	Slate Grey	Mountain Blue	White	Clay Brown
------------	-------------	------------	-------	-------	------------	------------	------------	---------------	-------	------------

Colorsteel Colours

Perma-ment Green	Karaka	Mist Green	Ebony	Desert Sand	Cloud	Gull Grey	Iron Sand	Denim Blue	White	Lignite
------------------	--------	------------	-------	-------------	-------	-----------	-----------	------------	-------	---------

Please note that the colours represented above are the best match possible within screen and printing variations. Colorsteel colours are a guide only not colour matches.

TT10 - 10,000 Litres

DIAMETER: 2.6 metres
HEIGHT A: 2.4 metres
HEIGHT B: 2.2 metres

WEIGHT: 225 kg
MANWAY: 435mm
OUTLETS: 2 x 50mm
THREAD: Brass BSP

TT05 - 5,000 Litres

DIAMETER: 1.9 metres
HEIGHT A: 1.9 metres
HEIGHT B: 1.8 metres

WEIGHT: 100 kg
MANWAY: 435mm
OUTLETS: 1 x 50mm
THREAD: Brass BSP

TT04 - 4,000 Litres

DIAMETER: 1.7 metres
HEIGHT A: 1.9 metres
HEIGHT B: 1.8 metres

WEIGHT: 75 kg
MANWAY: 383mm
OUTLETS: 1 x 50mm
THREAD: Brass BSP

TT007 - 750 Litres

LENGTH: 1.3 metres
HEIGHT: 1.0 metres
DIAMETER: 0.9 metres

WEIGHT: 30 kg
MANWAY: 435mm

TT006 - 600 Litres

DIAMETER: 0.86 metres
HEIGHT A: 1.2 metres
HEIGHT B: 1.1 metres

WEIGHT: 20 kg
MANWAY: 190mm
OUTLET: 1 x 50mm
THREAD: Brass BSP

FREE DELIVERY
 ALL SIZES WITHIN SOUTH ISLAND



CERTIFIED MATERIAL

Devan Tanks are manufactured from the highest quality food grade polyethylene which is ideally suited to our moulding technique giving long life and trouble free service. Polyethylene cannot rot or corrode, and is ultra violet stabilised for New Zealand's harsh environmental conditions. It will not leach or taint your drinking water.

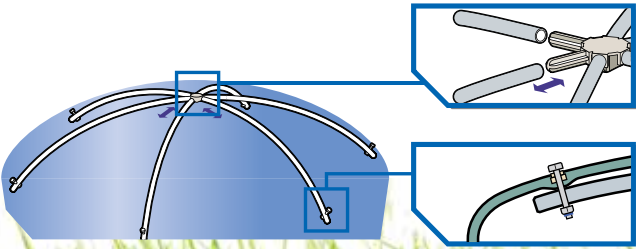

SUPER-STRONG DOME

The unique Devan Spaceframe provides for maximum strength in the dome of your tank which means it won't pop in when you are installing or servicing your tank nor will extreme snow loading have an effect. (Large tanks only)

ACCESSORIES

Devan have carefully selected a few key accessories to assist with your water collection, storage and use needs. Give some thought to what you may need to go with your tank and talk to one of the friendly team when ordering.



- First flush diverters
- Leaf/debris diverters
- Level indicators/gauges
- Plumbing kits
- Water pumps
- Pump Covers
- Uniseals
- UV systems
- Overflow kits
- Tank vents
- Float valves
- Connector kits



Christchurch Factory & Sales

PO Box 16720
26 Columbia Avenue, Hornby
Christchurch
Phone: 03 421 7340
Free Phone: 0800 500 026
Email: christchurch@devan.co.nz

Buy online or find more information @ www.devan.co.nz