



# Studio 2 Clean Air

In-Built Convector



## Installation Instructions

For use in NZ (New Zealand)

### IMPORTANT

THE OUTER CASING, FRONT AND GLASS PANEL BECOME EXTREMELY HOT DURING OPERATION AND WILL RESULT IN SERIOUS INJURY AND BURNS IF TOUCHED. IT IS THEREFORE RECOMMENDED THAT AN APPROVED FIREGUARD IS USED IN THE PRESENCE OF YOUNG CHILDREN, THE ELDERLY OR INFIRM.

CAUTION: THIS APPLIANCE SHOULD BE MAINTAINED AND OPERATED AT ALL TIMES IN ACCORDANCE WITH THESE INSTRUCTIONS.

Keep them in a safe place for future reference and when servicing the fire.

These products are tested in accordance with AS/NZS 4012:1999, AS/NZS 4013:1999 and AS/NZS 2918:2001 and comply with the NZ NES and ECAN emission requirements when using softwood

All installations must be carried out by an S.F.A.I.T (Solid Fuel Authorised Technician).

In New Zealand, the Studio must be bolted to the base to comply with the seismic restraint provisions of AS/NZ 2918:2001

## CONTENTS

### Studio 2 Clean Air (NZ) - In-Built Convector Instructions

Covering the following models: **RVST-2HTNZ**

<b>Commissioning .....</b>	<b>3</b>
<b>Appliance Description .....</b>	<b>5</b>
Appliance Performance .....	5
ECAN Approval No.....	5
Appliance Dimensions .....	6
<b>Cavity Construction .....</b>	<b>7</b>
Minimum Frame-out Dimensions .....	7
Typical Timber Frame-outs.....	8
ACC Block Heat Cell Cutting Schedule .....	9
Timber Frame-out with AAC Heat Cell.....	10
Masonry Inbuilt Enclosure Construction.....	12
<b>Pre-Installation Preparation .....</b>	<b>13</b>
Removal of the Door .....	13
Removal of Internal Components.....	14
Separating the Inner & Outer Box.....	18
<b>Installing the Appliance .....</b>	<b>19</b>
Flue Connection .....	19
Refitting the Inner Box.....	20
Finishing & Installation .....	21
Fitting the 25XS Steel Frame.....	23
<b>Technical Appendix.....</b>	<b>24</b>
Legal Requirements .....	24
Flue Outlet Positions .....	25
Flue & Chimney.....	26
Cavity Ventilation.....	28
Air Replacement Ventilation .....	29



#### Warranty

For purchases outside of the United Kingdom, Republic of Ireland, France, Belgium and the Netherlands, please consult your Stovax retailer for the warranty available in your region. The Fireplace [www.thefireplace.co.nz](http://www.thefireplace.co.nz)

## APPLIANCE COMMISSIONING SHEET

This checklist **MUST** be filled out completely and signed in order to qualify for the full Dealer Warranty. Failing to complete this commissioning checklist will mean the warranty will only be valid for 12 months from the date of purchase.

### Dealer appliance was purchased from:

Name: \_\_\_\_\_

Address: \_\_\_\_\_  
 \_\_\_\_\_  
 \_\_\_\_\_

Telephone number: \_\_\_\_\_

### Essential information - MUST be completed:

Date Installed: \_\_\_\_\_

Model Description: \_\_\_\_\_

Serial Number: \_\_\_\_\_

### Installation Technician:

Company Name: \_\_\_\_\_

SFAIT License No \_\_\_\_\_

Address: \_\_\_\_\_  
 \_\_\_\_\_  
 \_\_\_\_\_

Telephone number: \_\_\_\_\_

### Commissioning Checks - to be completed and signed:

Is flue system correct for the appliance:	YES <input type="checkbox"/>	NO <input type="checkbox"/>
Flue swept and soundness test complete*:	YES <input type="checkbox"/>	NO <input type="checkbox"/>
Smoke test completed on installed appliance	YES <input type="checkbox"/>	NO <input type="checkbox"/>
Spillage test completed	YES <input type="checkbox"/>	NO <input type="checkbox"/>
Use of appliance and operation of controls explained	YES <input type="checkbox"/>	NO <input type="checkbox"/>
Clearance to combustible materials checked**	YES <input type="checkbox"/>	NO <input type="checkbox"/>
Instruction book handed to customer	YES <input type="checkbox"/>	NO <input type="checkbox"/>
Smoke Alarm Fitted (Mandatory)	YES <input type="checkbox"/>	NO <input type="checkbox"/>
CO Alarm Fitted (Recommended)	YES <input type="checkbox"/>	NO <input type="checkbox"/>

\*If using an existing flue system - not applicable for a new flue assembly  
 \*\* Record with photographs if possible.

Signature: ..... Print Name: .....

## COMMISSIONING

To commission:

- Ensure all internal components (log guard, baffle(s), bricks) are correctly fitted.
- Check the door alignment and catch operation, adjust if required (see Maintenance and Servicing Instructions, Section 5).
- Check the soundness of door seals, castings and flue connections.
- Check the operation of the air control.

Now carry out a final smoke draw test:

- First warm the flue with a blowlamp, or similar, for about 10 minutes.
- Place a smoke pellet on the centre of the base bricks, with the air controls open.
- Close the door. Smoke should now be drawn up the flue and be seen to exit from the flue terminal.
- Complete test with all doors and windows closed in the room where the appliance is fitted.
- If there are any extractor fans in adjacent rooms, the test must be repeated with the fans running on maximum and interconnecting doors open.
- Check the effect of ceiling fans during the test.

If the test fails, re-check the suitability of the flue system and ventilation. **An inadequate air supply to the room is potentially dangerous.**

- Light the appliance and slowly increase the temperature to normal operating levels.
- Ensure no combustion products enter the room.
- Open the main fire door when the appliance reaches normal operating levels and carry out a spillage test with a smoke match or pellet around the door opening.

If excessive spillage occurs:

- Allow the appliance to cool and re-check the flue system and ventilation, see troubleshooting guide pages in User Instructions

**Finally:**

- **Explain the safe operation of the appliance and the use of the controls to the user and the importance of only using suitable fuels.**
- **Explain the cleaning and routine maintenance requirements.**
- **Explain the requirement to use a suitable fireguard when children, elderly or infirm persons are near the appliance.**

## IMPORTANT

- **Record dealer/supplier details and installer details on page 3 of this manual.**
- **Record serial number in page 3 of this manual.** This number is required when ordering spare parts and making warranty claims.
- **Give this instruction manual to the customer.**



**These steps MUST be completed in order to qualify for the full dealer warranty.**

**Failing to complete the commissioning checklist on page 3 will mean the warranty will only be valid for 12 months from the date of purchase.**

# Installation Instructions - Appliance Description

## PLEASE NOTE

This section is intended to give an overview of the product performance and essential information required for installing the appliance. It is intended for qualified technicians who are already familiar with Stovax products.  
**For full details and expanded information please see the Technical Appendix at the back of this manual.**

## ESSENTIAL INFORMATION

### AUTHORISATION NUMBER: 133649



The Studio 2 Clean Air NZ has been authorised by Environment Canterbury as meeting the emissions and efficiency criteria.

<b>GENERAL</b>	<b>Model:</b>			
	<b>Studio 2 Clean Air (NZ)</b>			
	Nominal Heat Output	Wood	kW	12.0
	Room Heating Capacity	Wood	m <sup>3</sup>	210
	Particulate Emissions	Wood	g/kg	1.0
	Efficiency	Wood	%	66
	Weight		Kg	160
Recommended Fuels	Soft Wood	Seasoned Soft Wood (less than 20% moisture content)		

As tested to the requirements of AS/NZ 4012:1999 & AS/NZ 4013:1999.

<b>FLUES</b>	Flue/Chimney Size	Factory made system (diameter) Installed in accordance with manufacturers instructions	mm	150/ 200/ 250
	Flue/Chimney minimum height from hearth level**	All products  **must be 4.5m from the appliance to the top of the flue, with no horizontal sections and a maximum of 4 bends. Bends must have angles of less than 45 degrees off the vertical.	m	4.6
			feet	15
	Flue Draught	Min	mm Wg	1.0
		Nominal		1.5
		Max		2.0
Flue Outlet Size (Top Option)		mm	153	
		inch	6	

<b>VENTILATION</b>	Cavity Ventilation - Page 28	∅	100mm x 2
	Room Air Replacement - <b>SUGGESTED MINIMUM</b> (vents x 2) - See Page 29	mm	175 x 175

For full technical details on ventilation see Technical Appendix on Page 28



\*When measured from the top of the appliance to the top of the flue, with no horizontal sections and a maximum of 4 bends with angles of less than 45°. Bends should be installed as high as possible in the flue run and only after the first flue run of 1.2M.

**\*\* DO NOT PLACE ANY OFFSET BENDS DIRECTLY INTO THE FLUE SPIGOT ON THE FIREBOX UNLESS THE DEFLECTION OFF THE VERTICAL IS 10 DEGREES OR LESS. NO BENDS OFF THE TOP OF THE APPLIANCE.**

# Appliance Dimensions

## GENERAL POINTS

Each installation is unique to the property so it is not possible to give details to suit every setting. The installation must comply with Building Regulations and be made using "best practice" construction methods.

Stovax Studio appliances can reach high temperatures so it is important to maintain the clearance to heat sensitive materials.

Take care when installing the appliance. Careless handling and use of tools can damage the finish and/or area.

All methods of installation will require the attachment of frame fixing brackets prior to the installation of the outer box see Frame Section, Page 23.

Refer to the diagrams and dimensions on the following pages when building a frame out to house the appliance.

## STUDIO DIMENSIONS

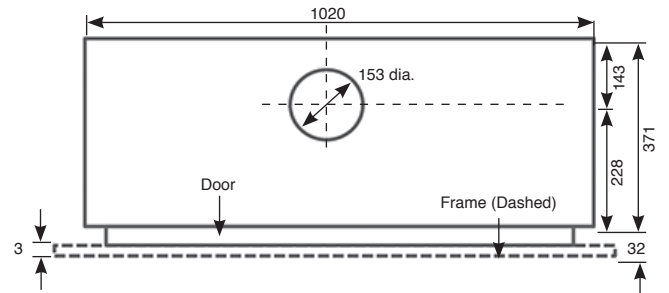
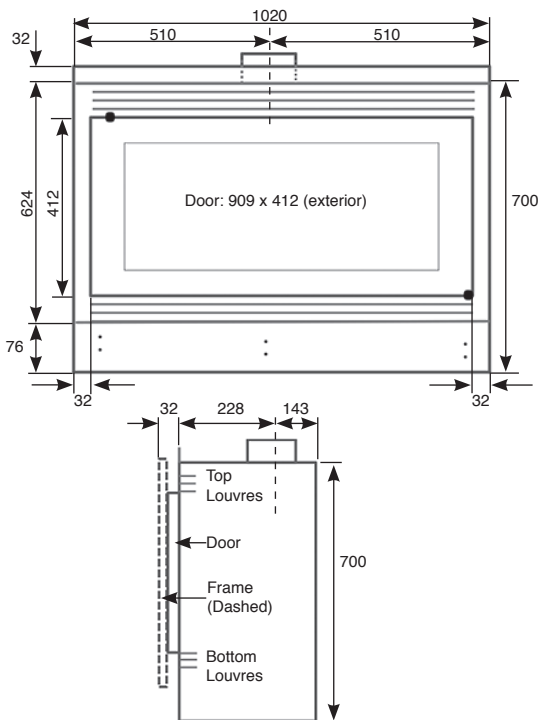

25XS Steel Frame Dimensions

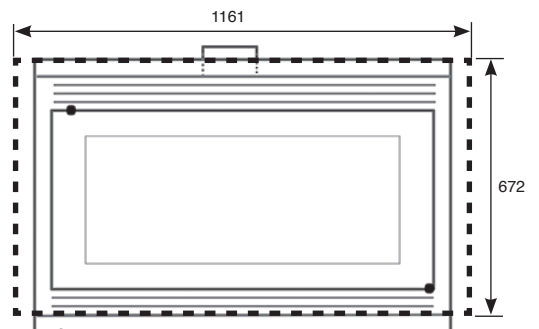

## MINIMUM DIMENSIONS - FLOOR PROTECTOR

### In-Built Convector

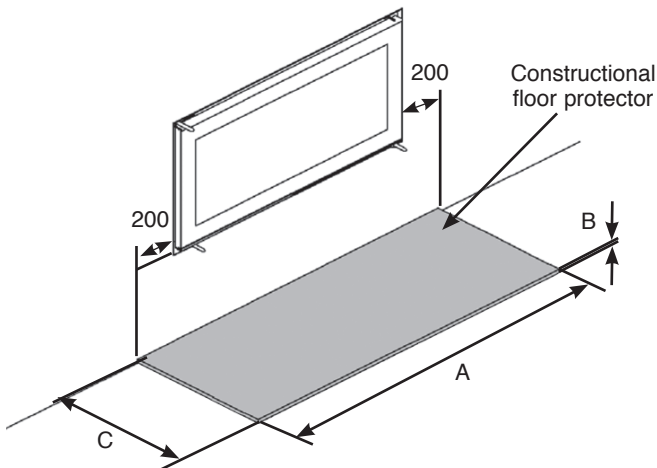

DIMENSION	A	B	C
Studio 2 Floor Level or <300mm	1350	24	300
Studio 2 raised above 300mm	1350	12	300

# Cavity Construction - Minimum Frame-Out Dimensions

## MINIMUM DIMENSIONS -TYPICAL TIMBER FRAME OUT WITH AAC HEAT CELL

Framing using 90mm x 45mm timber

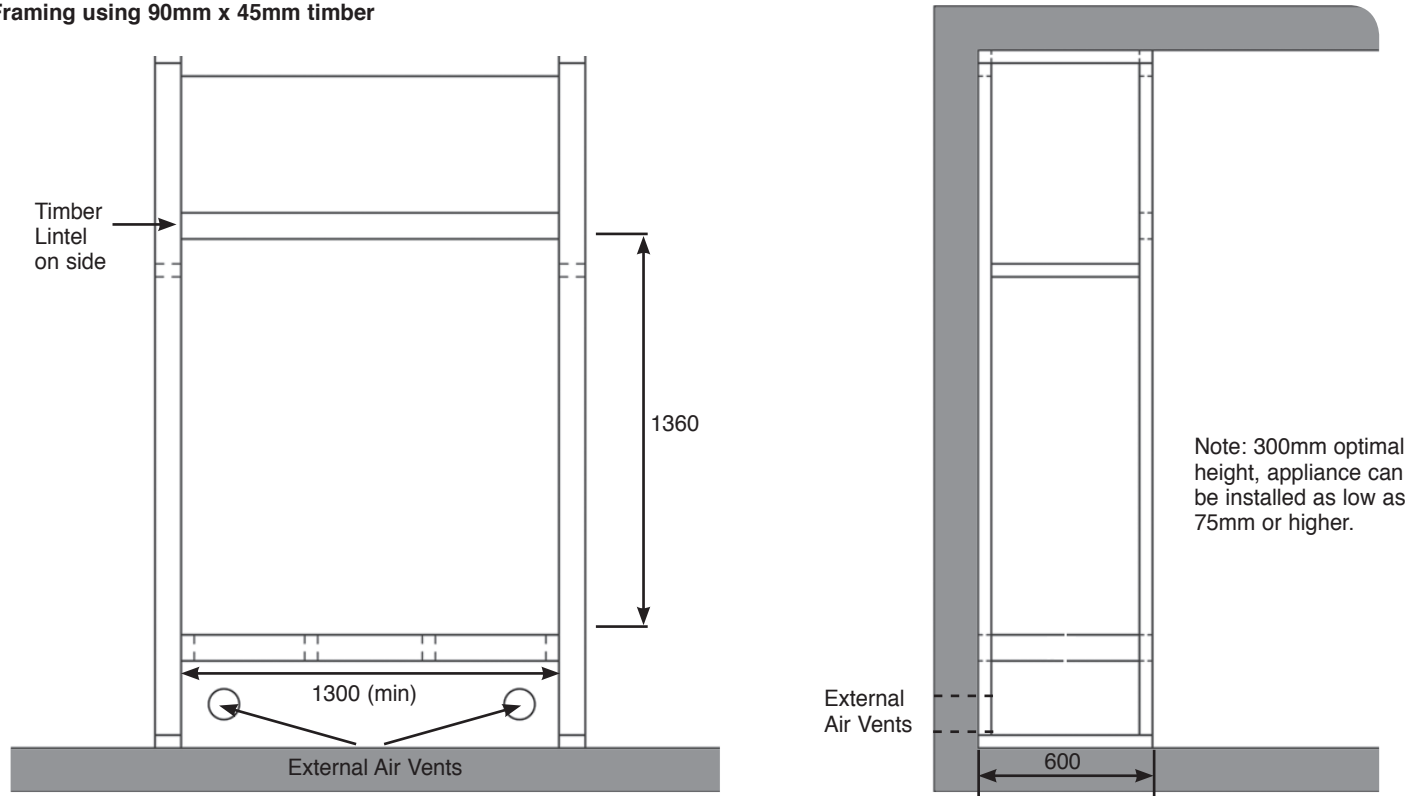

Please refer to page 28 for alternative venting options.

**Note:** Please contact The Fireplace to discuss installations when recessing the appliance, installing mantels and TV's or paintings above the appliance.



Timber Frame-out with AAC block panels and air vents

# Cavity Construction - Typical Timber Frame-outs

## FRAMEOUT EXAMPLES

The following standard frame out details are typical of those required for installing these fires into the following situations;

**Diagram 1:** Internal Timber framed chimney chase on an external wall

Variations to all of the basic frame out details will no doubt occur with designer preferences.

Any variations should be checked with your Stovax retailer or The Fireplace before construction.

Note: For instructions on inbuilt masonry installation refer to Pg9.

## INTERNAL TIMBER FRAME CHASE ON AN EXTERNAL WALL

Diagram 1 Plan View

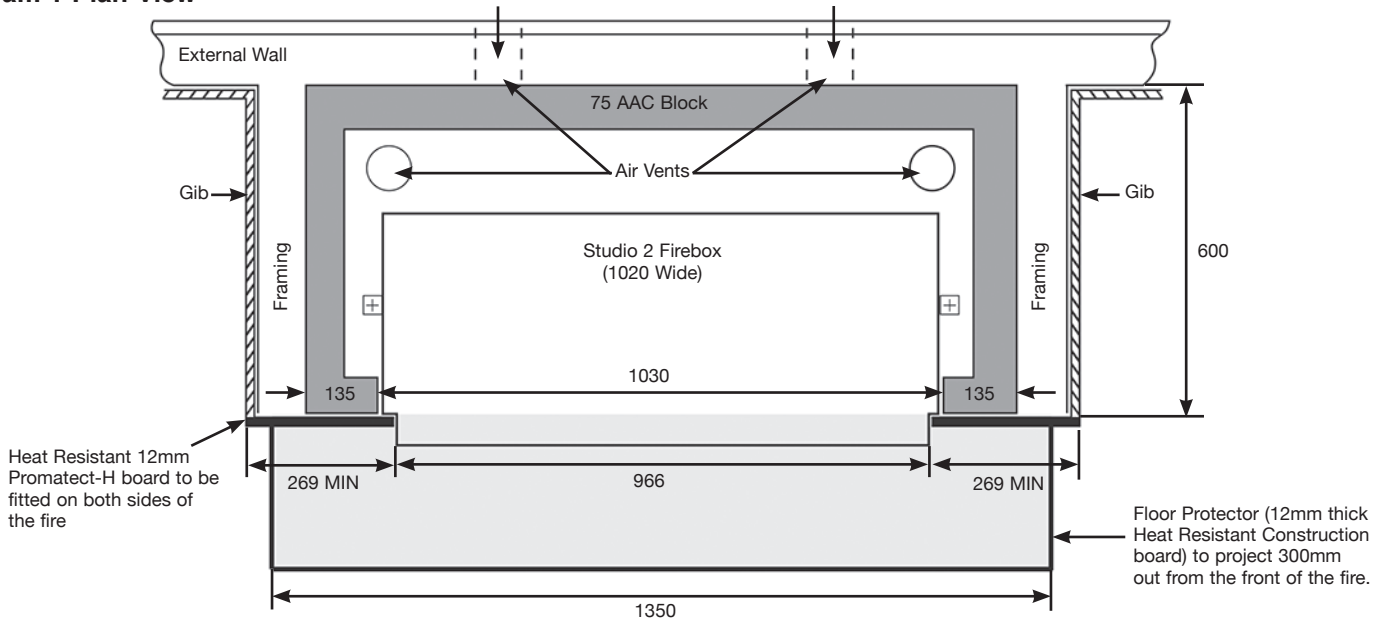

## EXTERNAL TIMBER CHIMNEY CHASE ON AN EXTERNAL WALL

Diagram 2 Plan View

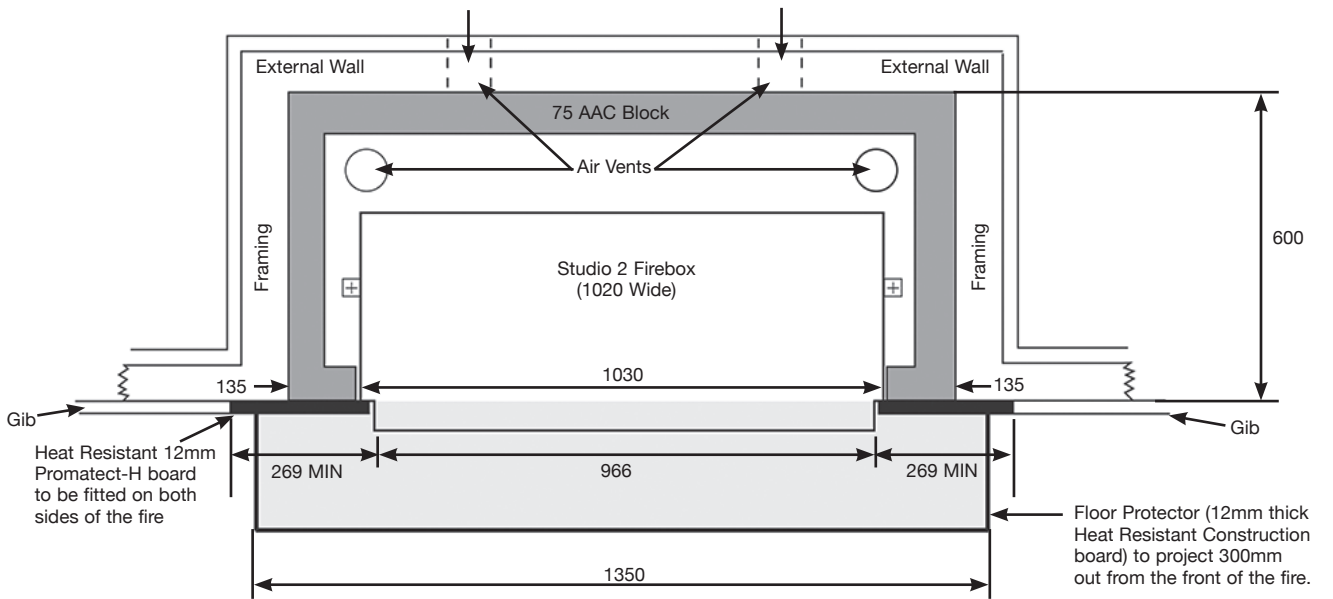



# Cavity Construction - Frame-out with AAC Heat Cell

## AAC BLOCK HEAT CELL CUTTING SCHEDULE

There will be many alternative cutting schedule scenarios able to be incorporated depending on individual installer preferences. The above schedule is based on one version that is the MINIMUM requirement in terms of panel spacing's and required clearance dimensions to the firebox.

A	Floor slab	2 x 650 x 600
B	Front Top Panel	1 x 1150 x 490
C & D	Front Face Panels	2 x 710 x 65
E & F	Back Panels	2 x 1150 x 600
G & H	Side Panels	2 x 1200 x 600
J & K	Top Lid Panels	2 x 500 x 600
L & M	Front & Rear Lid Make Up Panels	2 x 300 x 100

## AAC BLOCK EXPLODED VIEW

The following panels for the HEAT CELL are based on being cut from 1200 x 600 x 75 AAC Block Panels. Use AAC Block cement or Holdfast Gorilla glue to fix panels to one another.

### AAC Block Exploded View

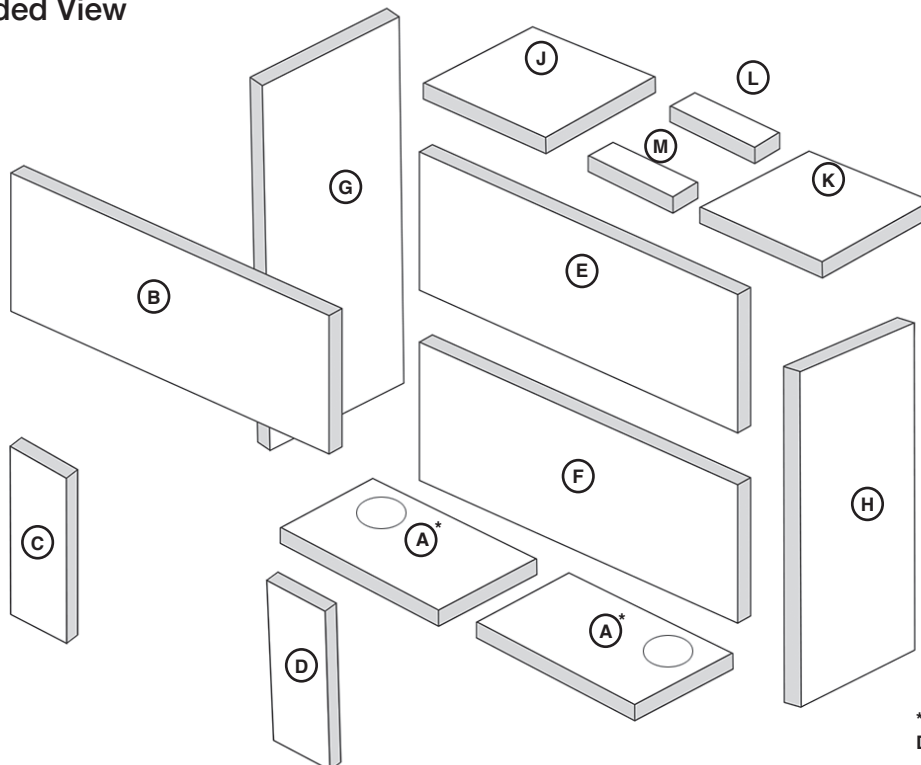

\*Add vent holes see page 11  
Diagram 3 for details.

# Cavity Construction - Frame-out with AAC Heat Cell

## INSTALLING THE APPLIANCE

**IMPORTANT: IT IS NOT RECOMMENDED TO POSITION LCD/PLASMA TV OR ARTWORK ABOVE THIS FIRE**  
 (Home owners take full responsibility if they choose to proceed with the above, please contact The Fireplace to discuss.)

Do not pack any voids around or above the appliance with insulation materials such as mineral wool or vermiculite.

PLEASE REFER TO PAGE 28 FOR ALTERNATIVE VENTING OPTIONS

The appliance can be installed in a timber frame. For dimensions of the opening required see Frame Out Dimensions, page 7.

Make 2 x 100mm  $\varnothing$  in the external wall behind the frame out. Ensure the holes are either side of the centre line of the installation, see Diagram 1.

**The holes must be 200mm above floor level or 200mm above the base of the appliance and open to unrestricted airspace.**

Build up the framework as required using 90mm x 45mm timber, see Diagram 2.

**Ensure the framework is secured to the wall and floor of the building.**

**Note: If the appliance is to be recessed please increase the cavity depth and height dimensions.**

**Allow a minimum of 40mm above the decorative steel fascia to allow air flow out, see page 22**

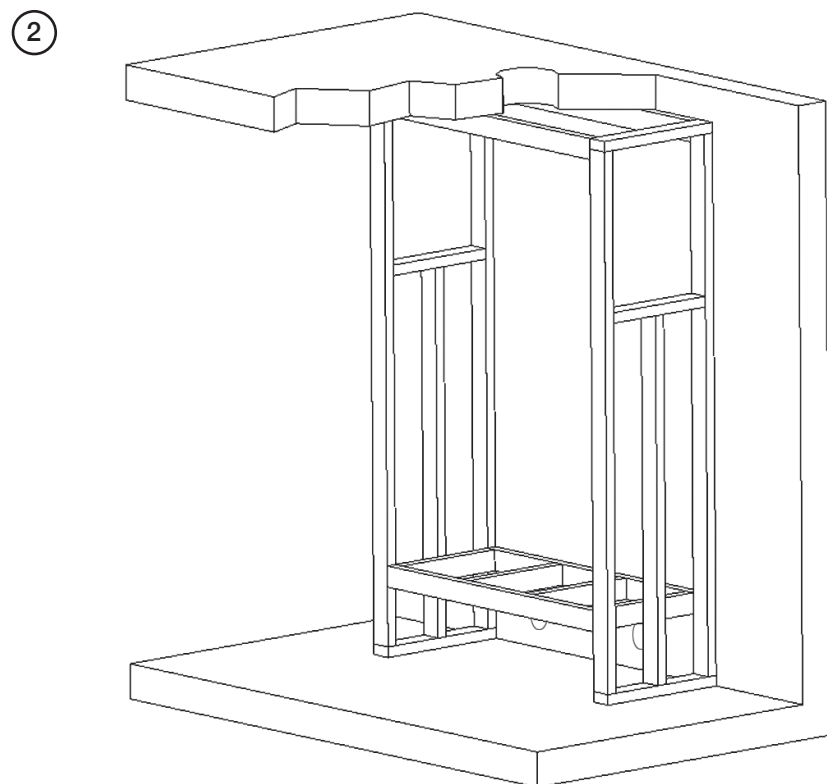
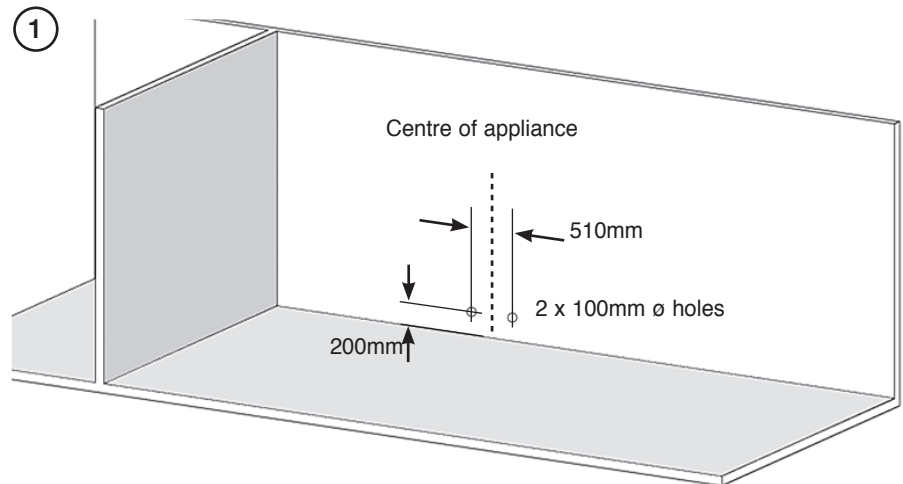

# Installation Instructions - In Built AAC Block Installation

Place 1 x 75mm AAC Block panels on the timber frame base.  
For dimensions of the AAC Block refer to the table in Installation Checklist on page 9.

Cut 2 x 100mm holes in the AAC Block base at each rear corner for ventilation or in the rear hebel panel depending on location of the outside air vents..

Cover with Mesh for vermin/bird proofing.

Install the side and back AAC Block panels, see Diagram 3.

③

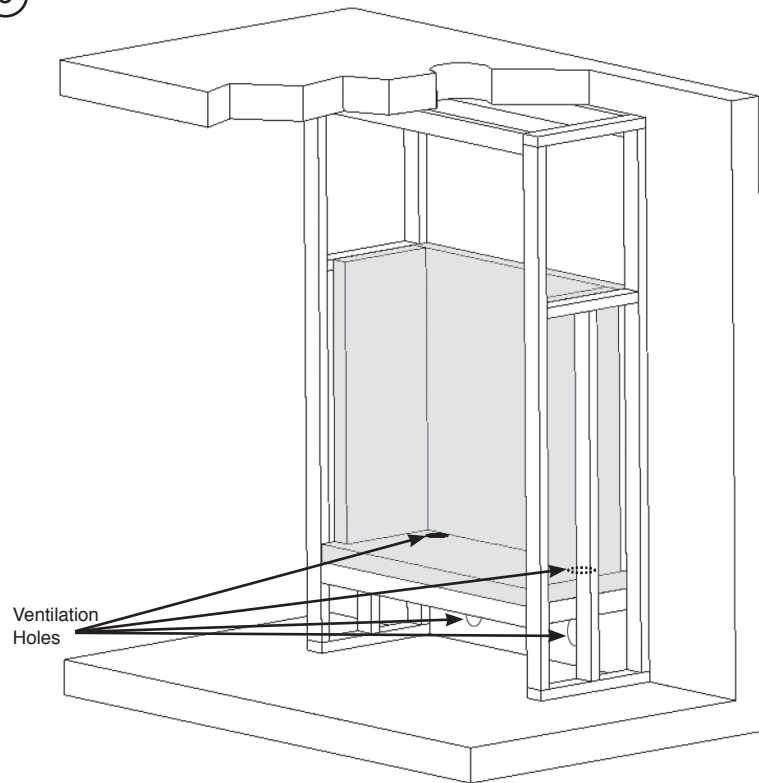

For ease of installation it is advisable to remove all the internal components from the appliance before fitting into the cavity.  
See Pre-Installation Section.

Install and fix the outer box into position on the AAC Block base.  
See Pre-Installation section for instructions on separating the inner and outer boxes.

Bolt the outer box base to the AAC Block base to comply with seismic restraint requirements.

Note: Use 2 x 6mm Rawl Bolts or similar approximately midway depth of the outer box and as close to the sides as possible

④

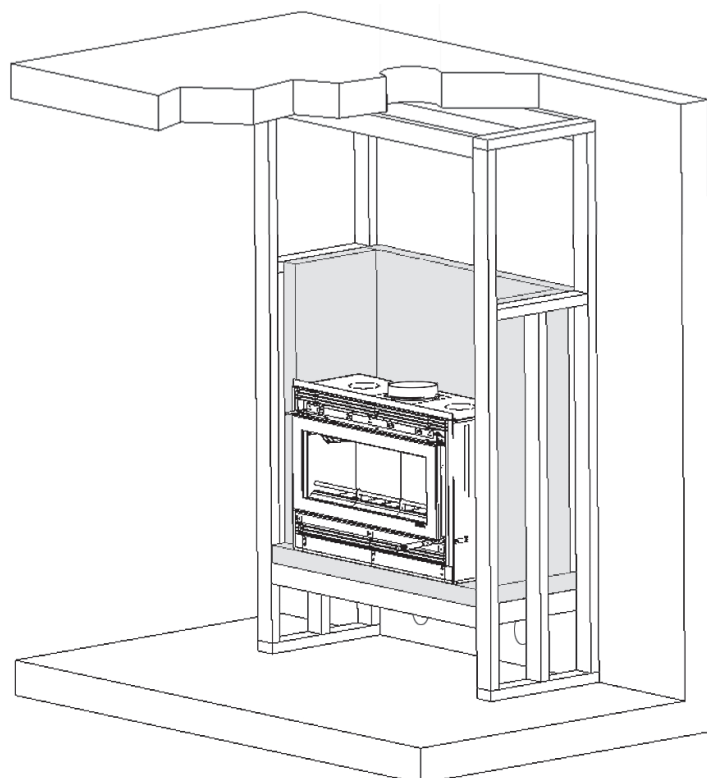

# Cavity Construction - Masonry In Built Enclosure

## MASONRY INSTALLATION

The following standard masonry cavity details is for a typical installation:

- For a full masonry walled construction, it is recommended to construct the masonry section above the fire such that a masonry lintel is placed 600mm above the firebox. This will enable the flue installation to be carried out at a later date.
- For an In-situ concrete structure ensure one side is left open or the cavity is increased in size to allow for the installer to fit the flue to the firebox.
- Other than the presence of AAC Block for the sides and back of the heat cells, dimensionally, everything is the same as for Diagram 1 & 2 on Page 8 including the floor protector. The finishing on the internal walls needs to be treated the same as detailed in the full STOVAX instruction details.

## A TYPICAL MASONRY WALLED CONSTRUCTION

### Plan View

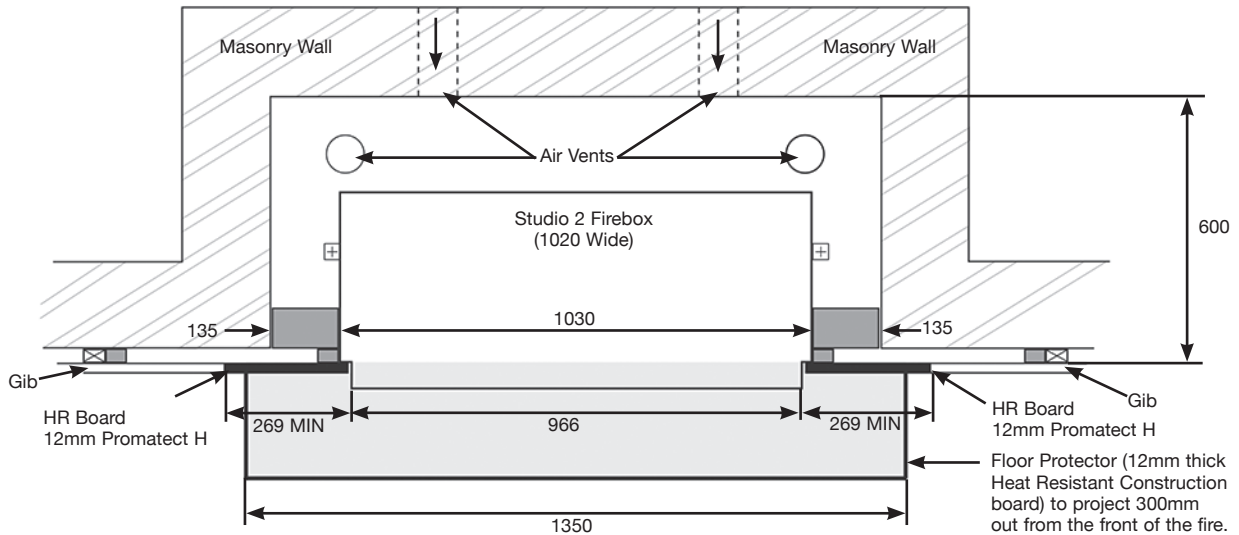

## MASONRY RECESS

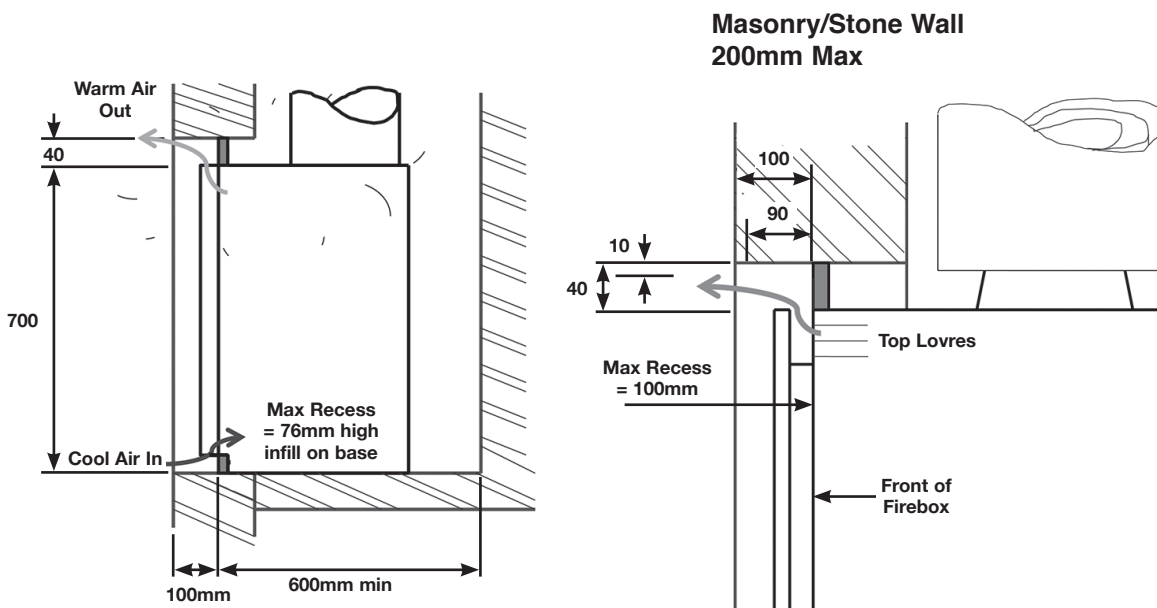

# Pre-Installation Preparation

## GENERAL

To make the installation of the appliance easier it is best to remove all internal components before fitting into the builders opening/studwork.

For the best results removing the following components as set out below.

## REMOVAL OF THE DOOR

Before removing the door it is recommended to protect the left edge from damage using masking tape.

Open the door approximately 90°, see Diagram 1.

Move the Air Control to the far right, see Diagram 2.

Lift the door vertically to remove from the hinge block, see Diagram 1.

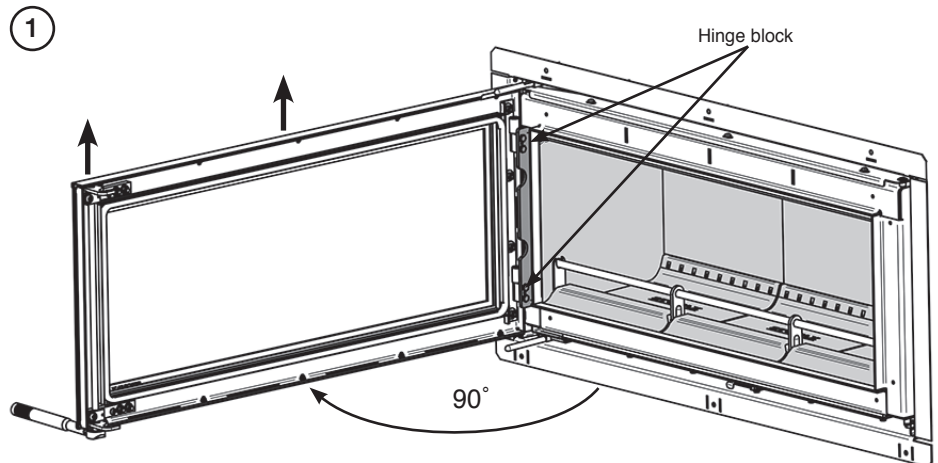

Close the door 45°, ensuring the Air Control handle sits inside the channel in the top of the door, see Diagram 2 and carefully manoeuvre the door clear of the hinge mechanism.

Lie the door face down on a soft flat surface to protect the paint work and glass.

Reverse the procedure to re-fit the door.

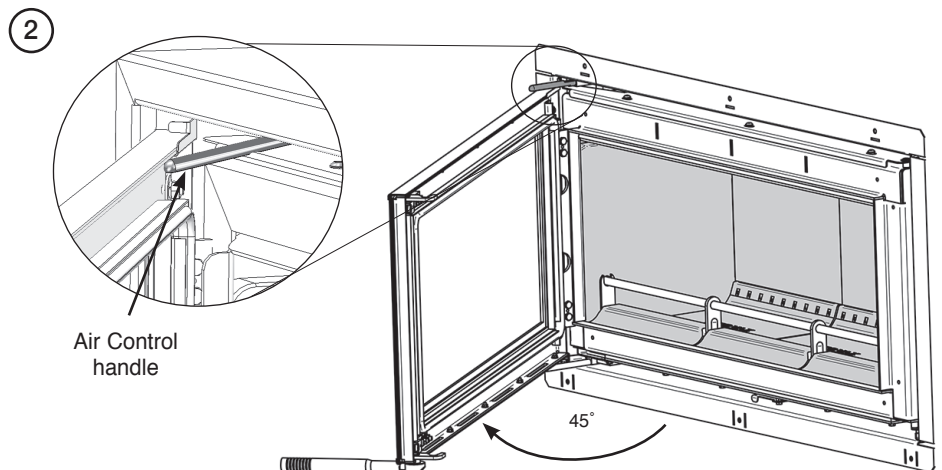

# Pre-Installation Preparation

## REMOVAL OF THE LOG GUARD

To remove the Log guard:

— Slide the Log Guard across to free from the holes in the side bricks, See Diagram 3.



**IMPORTANT: ALWAYS LIFT AND HANDLE THE BRICKS WITH TWO HANDS AT ALL TIMES. FAILURE TO DO SO MAY DAMAGE OR CAUSE BREAKAGES DUE TO UNEVEN PRESSURE WHILE HANDLING THE BRICKS.**

— Raise one end and with draw at an angle through the front of the firebox, see Diagram 4.

**Do not use appliance without the log guard in position.**

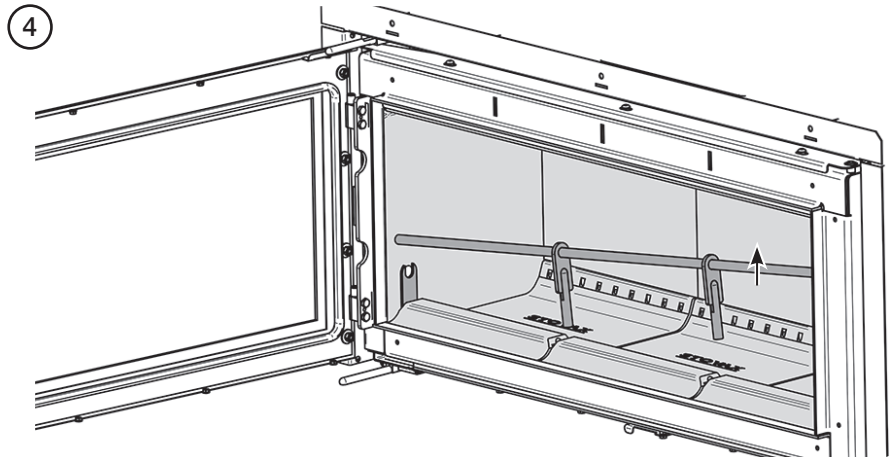
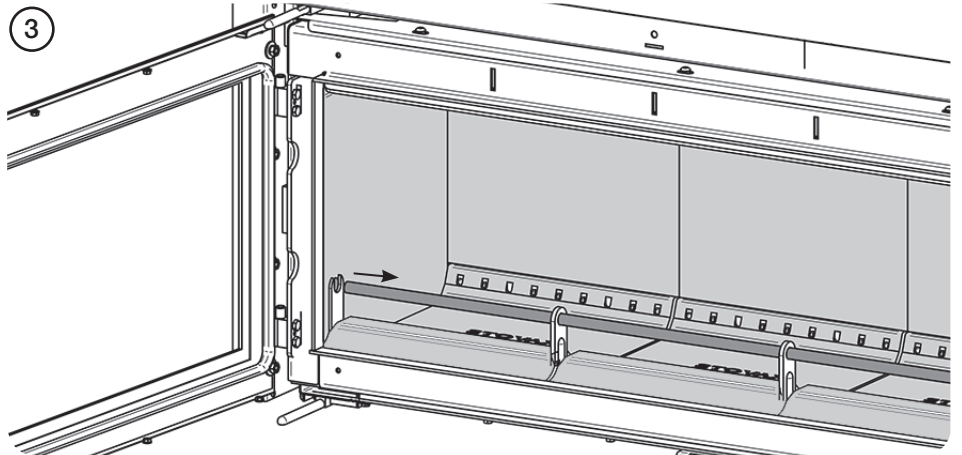

## REMOVAL OF INTERNAL COMPONENTS

In the firebox of the Studio are several loose items including:

- A box containing:
  - Baffle Bricks
  - Firebricks
  - Bag containing Instruction Manual, Warranty & Door Tool, Log Guard End Supports
- Log Guard
- Front Baffle Support

Remove these carefully and put them safely to one side. They can be fitted after the appliance has been installed, see Installation Section.

## REMOVAL OF THE FIRE BRICKS

Remove the fire bricks as part of the routine maintenance. This can be carried out without the use of tools.

Allow the appliance to cool fully before removing firebricks.

Take care when handling, as bricks can become fragile after use. Life span depends on the type of fuels burnt and the level of use.

**Important: Do not attempt to remove the base bricks before removing the side and rear bricks. Bricks should only be removed in the order described below.**

# Pre-Installation Preparation

Replace damaged bricks as soon as possible.

Remove the firebricks in the following order:

1. Tilt the side bricks into the middle of the appliance and remove.
2. The rear bricks can now be tipped forward starting from either end and removing the middle brick last.
3. The base bricks can now easily be lifted clear.

Replace in reverse order.

Once the bricks have been removed from the appliance ensure they are stored in an area where they will not be damaged.

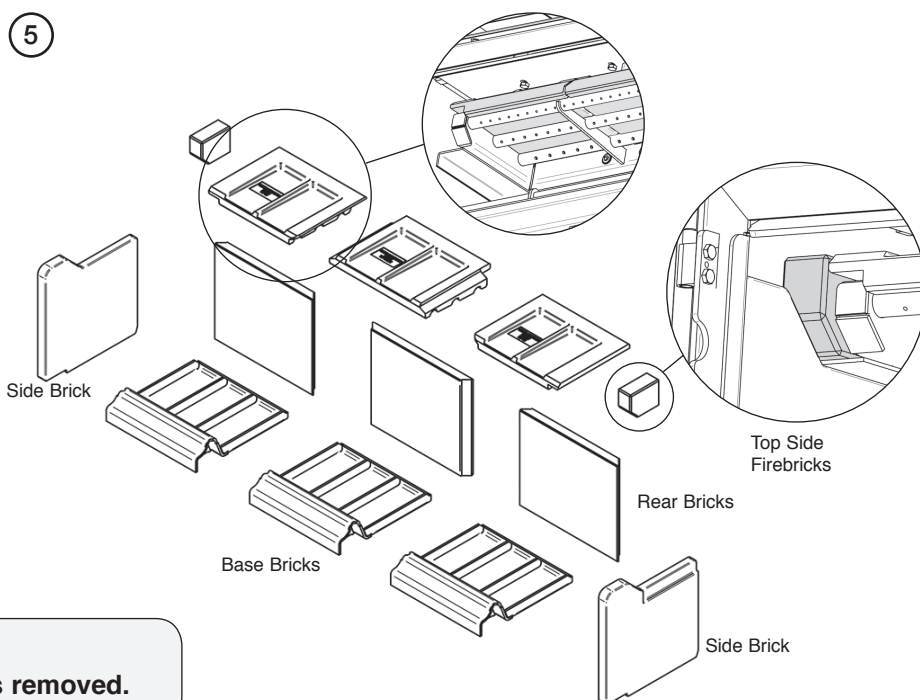

**i Do not modify baffle bricks. Do not operate with baffle bricks removed.**

## REMOVAL OF THE BAFFLE BRICKS (VERMICULITE)

The appliance is fitted with 3 baffle bricks at the top of the firebox and two side bricks to maintain efficient combustion.

Allow the appliance to cool fully before removing baffle system.

Remove the Log Guard from the appliance to give access to the firebox, see Pre-Installation, Removal of the Log Guard.

Carefully pull out the side Firebricks forward from their position at either end of the metal baffle rail.

You can now access the main baffle bricks. These have grooves on the underside which fit over the metal baffle rail.

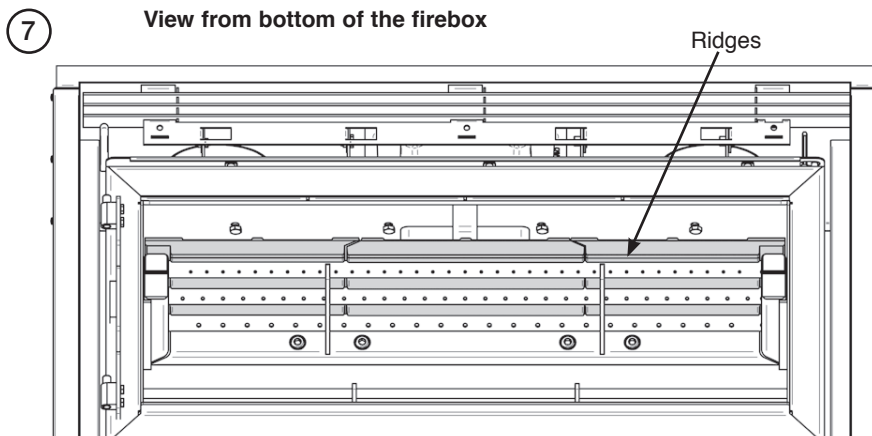
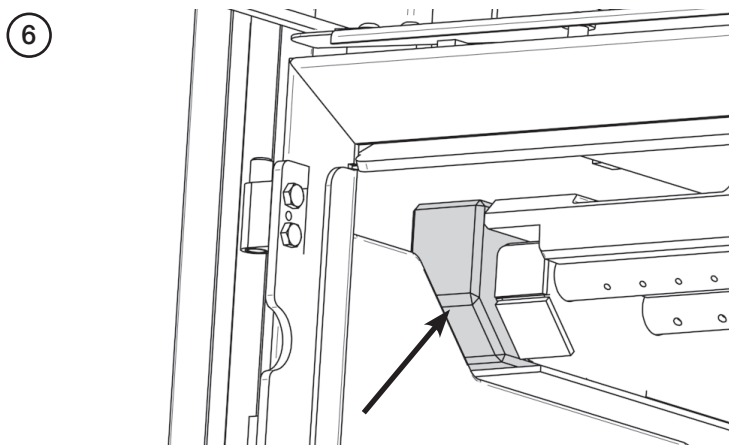

# Pre-Installation Preparation

Starting from the right carefully lift the baffle bricks out from their position on the baffle rail, see Diagrams 8 & 9.

8

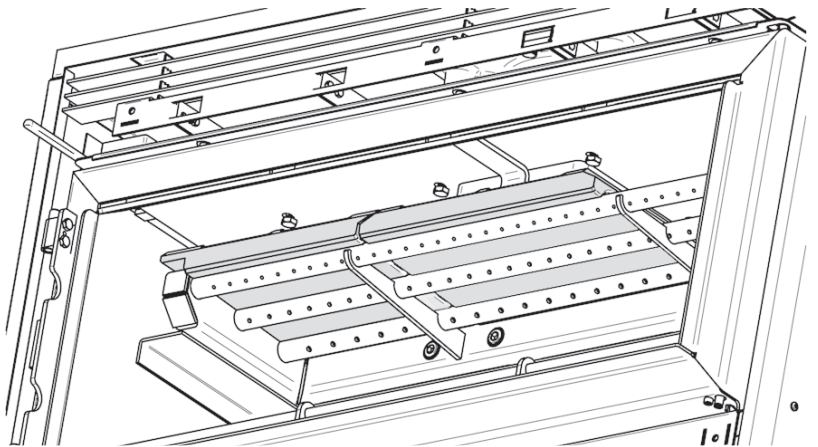

Follow these instructions in reverse order to fit the baffle bricks. Replace damaged baffles immediately.

9

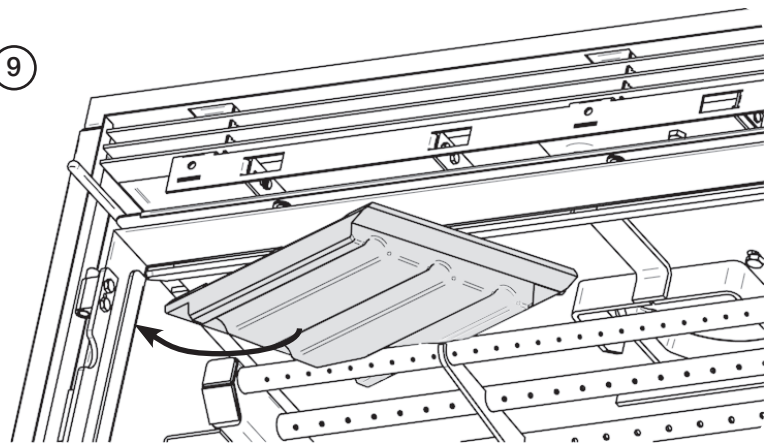

## REMOVAL OF THE BAFFLE PLATES (STEEL)

There is an additional baffle consisting of two steel plates at the top of the firebox.

10

To release the baffle start with the Left Hand Side plate and ensure that it is supported.

Remove the bolts and carefully lower the baffle out of the firebox.

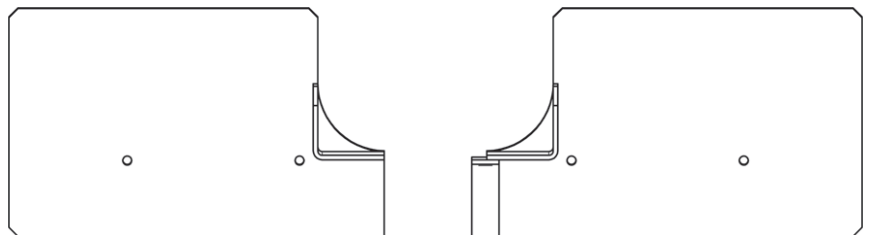

Repeat with the Right Hand Side plate.

Replace in reverse order

The baffle system is designed to give safe and efficient operation of the stove. Replace damaged baffles immediately.

**Do not modify the baffle system.**  
**Do not operate with the baffle plates removed.**

11

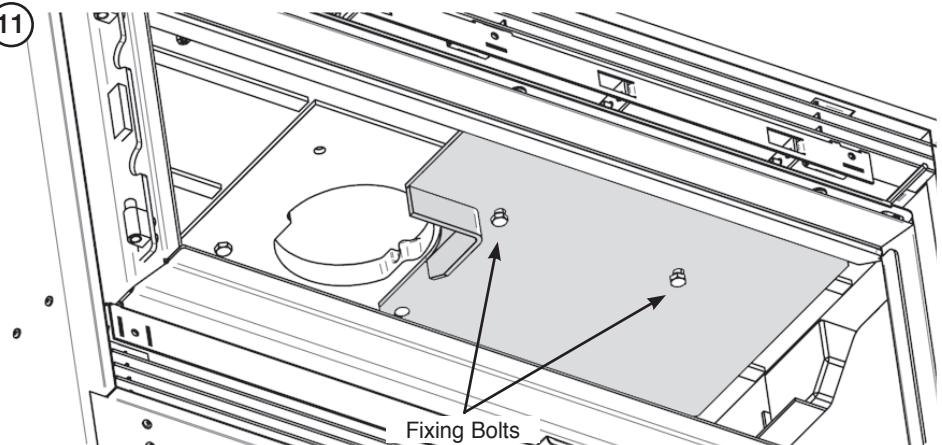



# Pre-Installation Preparation

## REMOVAL OF THE FLUE COLLAR

Remove the 4 fixing bolts.

12

Remove the inner flue collar.

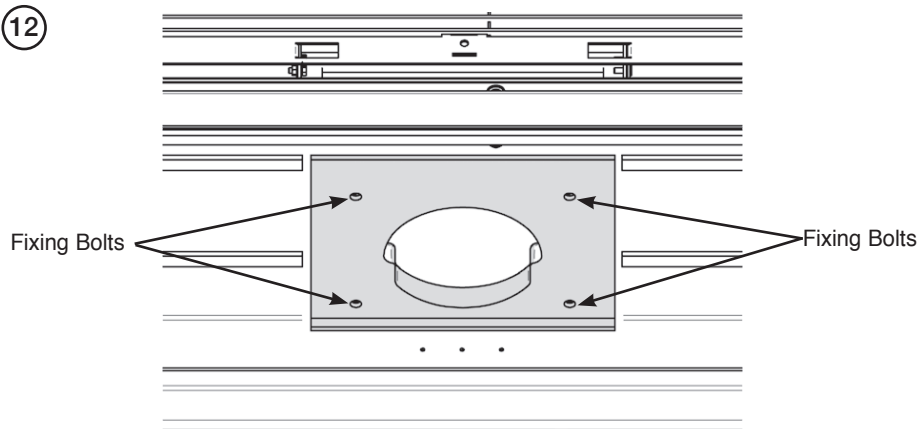

## REMOVAL OF THE AIRBAR

First remove the side and top baffle bricks, see Removal of the Baffle Bricks (Vermiculite) Section.

13

The Airbar is secured to the inner box by four screws.

Lift one end carefully and manoeuvre the airbar out through the front of the firebox.

Replace in reverse order

The airbar is designed to give safe and efficient operation of the stove. Replace damaged parts immediately.

**Do not modify the airbar system.**

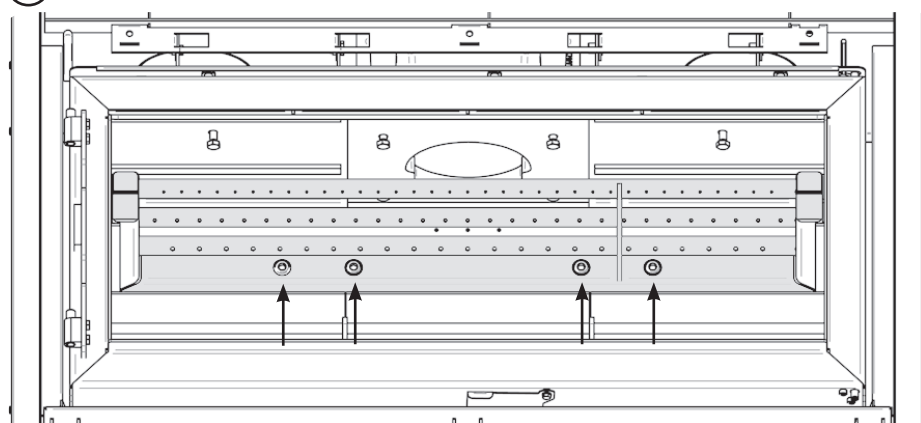

## LOUVRES

The appliance has detachable louvres to help direct convected air into the room where it is installed. The louvres sit in channels above and below the inner box.

To remove, pull the metal slats from the channels and place carefully to one side.

To refit the slats slide into the channels ensuring they are fitted so the sides are equal distance from the edges of the box.

# Pre-Installation Preparation

## SEPARATE THE INNER & OUTER BOX

**This will require two people.**

To protect the delicate parts of the appliance the product has been designed so that the inner box can be removed from the outer box.

Keep the inner box in a safe place whilst the outer box is installed into the fabric of the house, the main flue connections made and the walls finished.

When all the heavy work is complete the inner box can be re-installed into the outer box and the final connection made.

**Take care when installing the appliance. Careless handling and use of tools can damage the finish of the appliance and/or area it is being installed into.**

The internal components, bricks, baffles and the door etc should be removed to make the installation process easier and prevent damage.

The inner box can now be slid out of the outer box.

14

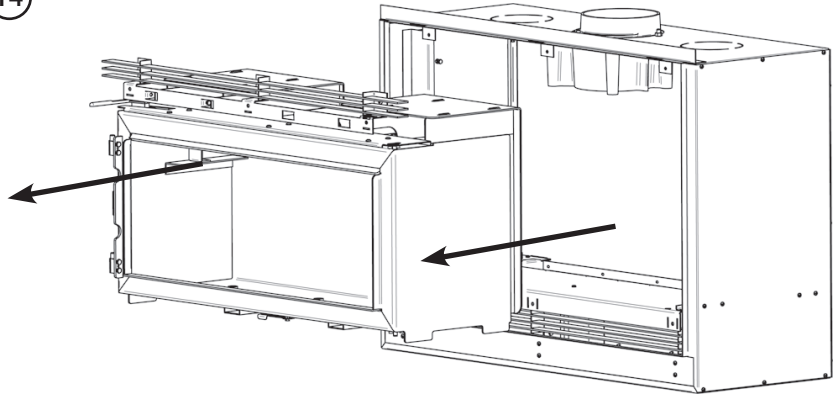

15

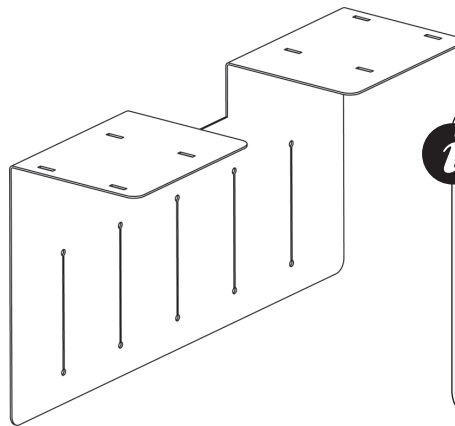

The Studio also has a heat shield that fits between the inner and outer case. This sits on the top of the inner box and is held in place by it's own weight.  
**CAUTION: THIS IS EXTREMELY HEAVY.**

# Installation Instructions - In Built AAC Block Installation

## FITTING THE FLUE SYSTEM

Fit the triple wall flue system in accordance with the manufacturers instructions and AS/NZS 2918:2001 ensuring the centre and outer skins are supported in the box brackets to maintain the required clearances, see Diagram 1

Ensure a gap of 25mm is maintained between the firebox and the 200 diameter and 250 diameter intermediate and outer flue pipes. A bottom spider is usually adopted for this purpose.

NOTE: Flue system must be installed as per 2918:2001 Section 4.1.  
NO 45 DEGREE BENDS OFF THE TOP OF THE FLUE AND WITHIN THE FIRST 1200MM FLUE RUN., MAXIMUM OFFSET 10 DEGREES. AXIS OF THE FLUE SYSTEM SHOULD BE AS VERTICAL AS POSSIBLE

①

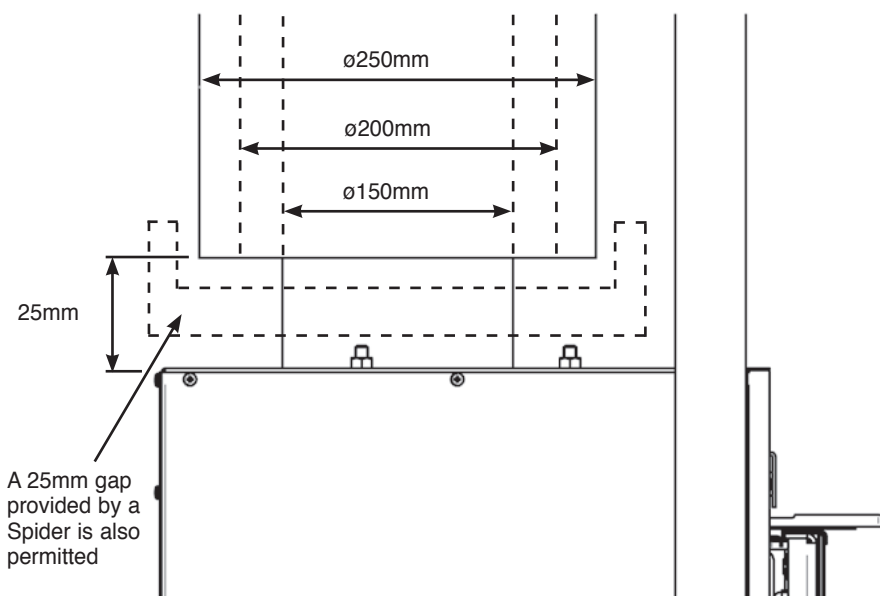

The connection to the firebox flue collar, requires a flue adaptor (supplied) to be inserted and sealed with high temperature sealant, before the first flue spigot is inserted\*.

This example shows the use of a 10 degree offset bend (to the rear) which was used to align to a specific existing roof penetration. This is to minimise any smoke nuisance resulting from changes in flue direction, particularly when the door is opened for refuelling.

Use mesh screening to prevent deleterious material or birds/vermin from entering the firebox cavity.

Side support brackets add rigidity to the flue installation.

**\*NOTE: Run a bead of sealant around the swaged end of the flue adaptor, before engaging into the flue collar. DO NOT PUT ANY SEALANT INTO THE FLUE COLLAR.**

②

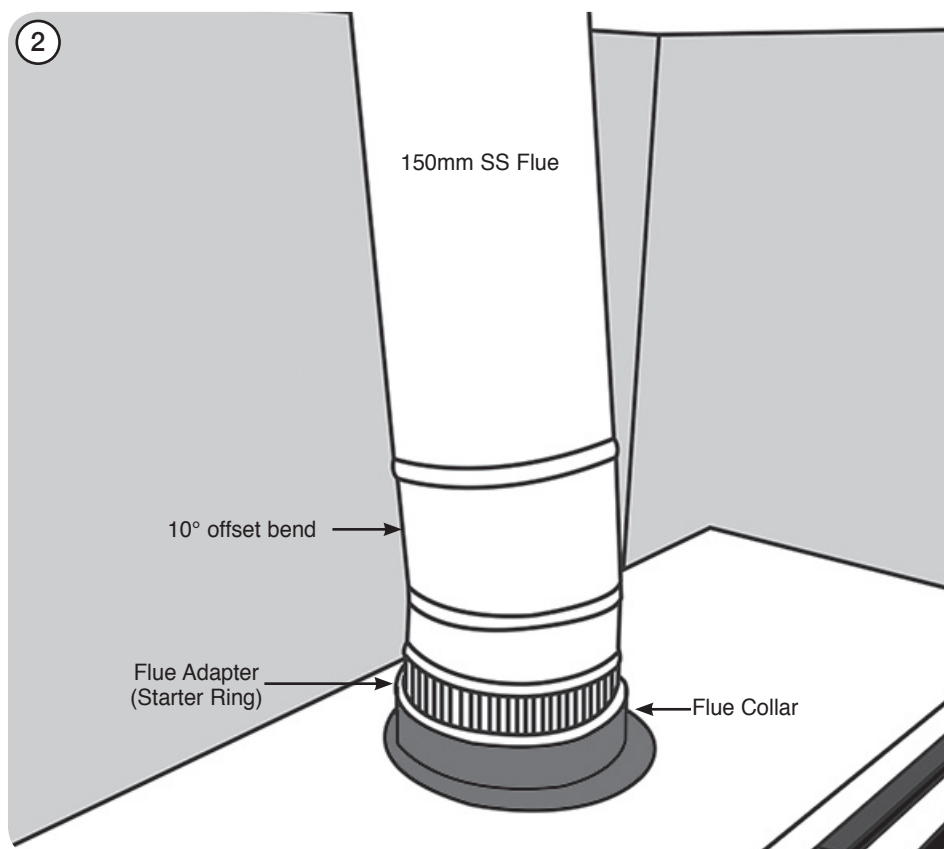

# Installing the Appliance - Refitting the Inner Box

## REFITTING THE INNER BOX & COMPONENTS

Once the flue is installed the inner box can now be refitted.  
This will require two people.

The inner box can now be slid into the outer box.

When refitting the cast iron flue collar ensure that it is sealed with fire cement.

Take care when installing the appliance.  
Careless handling and use of tools can damage the finish and/or area.

The internal components, bricks, baffles and the door etc can now be fitted into the appliance, see Pre-installation section Page 13-17.

Commission the appliance, refer to Page 3 & 4.

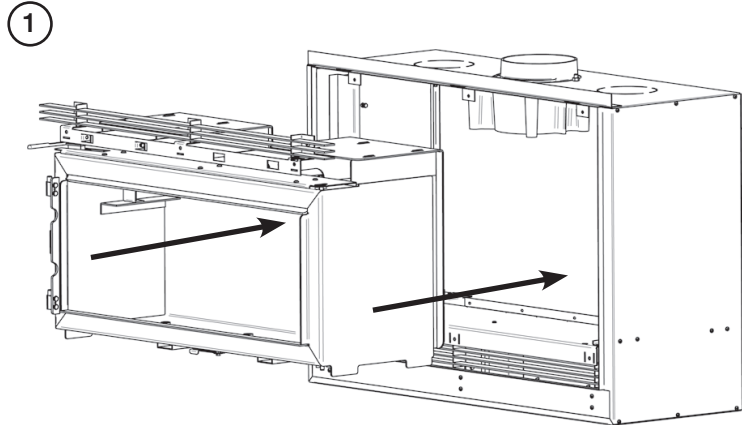

# Installing the Appliance - Finishing & Installation

## CLEARANCES TO COMBUSTIBLES - NON COMBUSTIBLE ZONE

- The appliance can be installed in a timber frame out.
- The following details are the absolute minimum required based on using 90 x 45 framing.
- The following dimensions are based on a standard 75mm thick AAC Block and wall finishing using 12mm Heat Tolerant Board. If using tiles, stonework or similar provision must be made for the minimum clearances required for the bottom and top louvres.

Note: 300mm optimal height, appliance can be installed as low as 75mm or higher

Heat resistant board must extend a MINIMUM of 269mm to the sides and 600mm above the appliance and be at least 12mm thick.

**ANY INSTALLATION WORK MUST COMPLY WITH AS/NZS 2918:2001**

**ALL INSTALLATIONS SHOULD BE CARRIED OUT BY AN S.F.A.I.T (SOLID FUEL AUTHORISED INSTALLER TECHNICIAN) OR A PLUMBER TRAINED IN THE PRODUCTS INSTALLATION. FAILURE TO DO SO WILL NEGATE ANY WARRANTY(S).**

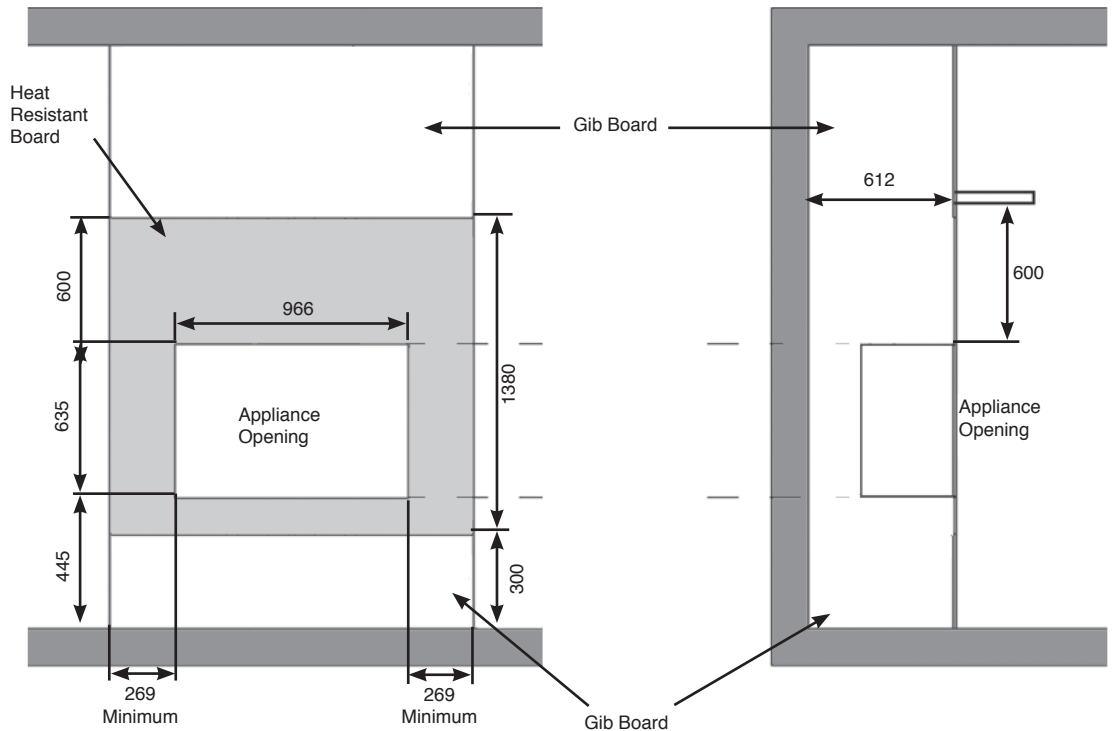

## STEPS FOR FINISHING THE INSTALLATION

Install AAC Block face panels to the sides and above the outer box. Lastly place a AAC Block panel lid to enclose the structure, see Diagram 1.

Cut a square mesh to enclose and rodent proof the area between the AAC Block and flue pipe.

Install a timber lintel on it's side (90mm x 45mm) above the AAC Block panel face above the outer box, see Diagram 1.

Ensure the panels slide into position behind the box flange outer box flange - refer to Page 21 for dimensions.

Install heat resistant board to the front face of the wall, See Diagram 3.

Fit remaining Gib board to enclosing the timber frame.

Cut 2 x 120mm air ventilation holes at the base and top of the enclosure on both sides of the framing.

①

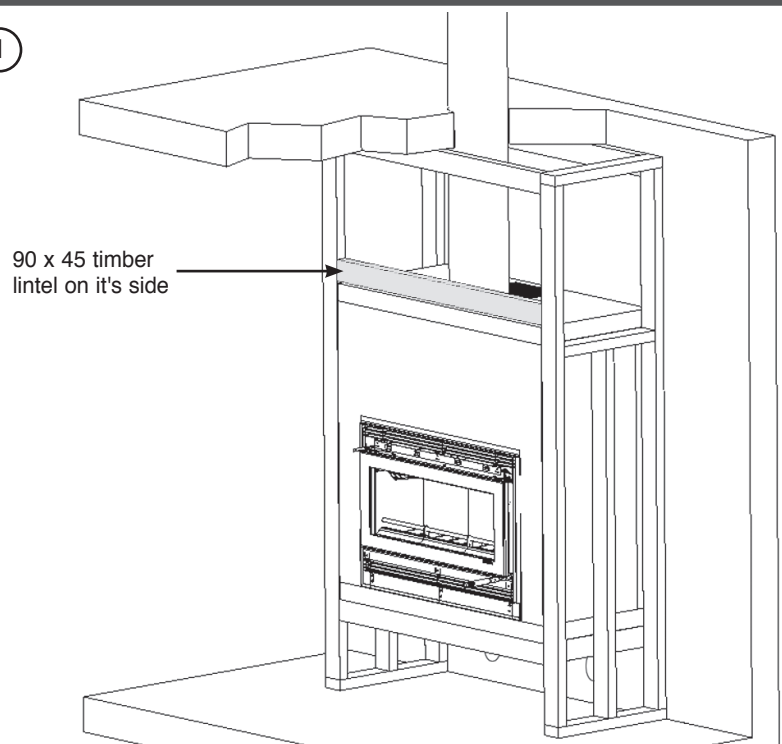

# Installing the Appliance - Finishing & Installation

2

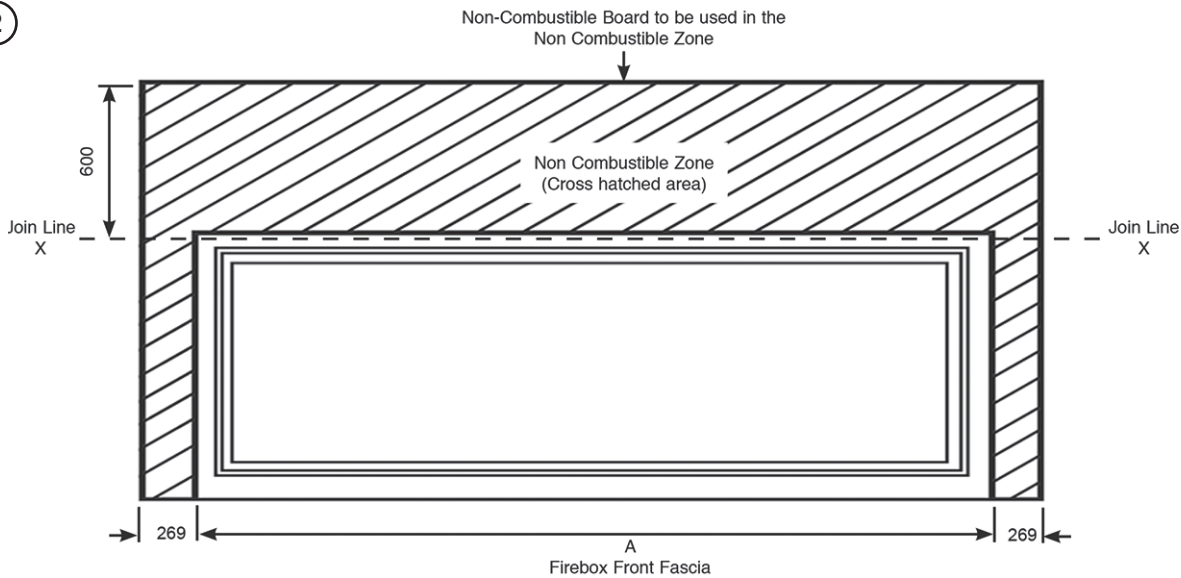

**Do not use mechanical fixings or heat sensitive sealants in the none combustibile zone. The edge shown as 'X - X' is to be floating and not fixed to the appliance fascia.**

The HR Board above the fire must be in one complete section cut to the width of the chimney chase (A,B). For the sides and top of the firebox in contact with the HR Board, allow a gap of 1 -2mm for heat expansion/ contraction. The Board must not touch the firebox in these areas.

Also ensure there is a 1-2mm expansion gap around the appliance when finishing with plaster, steel or other cladding materials  
DO NOT use any adhesives or mechanical fixings between the HR Board and the AAC Block panels within the Non Combustible zone, 600mm above the fire and within 200mm of each side of the fire.

Use mechanical fixings onto the framing studs (A,C and B,D) each side and to the top dwang above the fire (C,D)

**PLEASE REFER TO PAGE 28 FOR ALTERNATIVE VENTING OPTIONS**

3

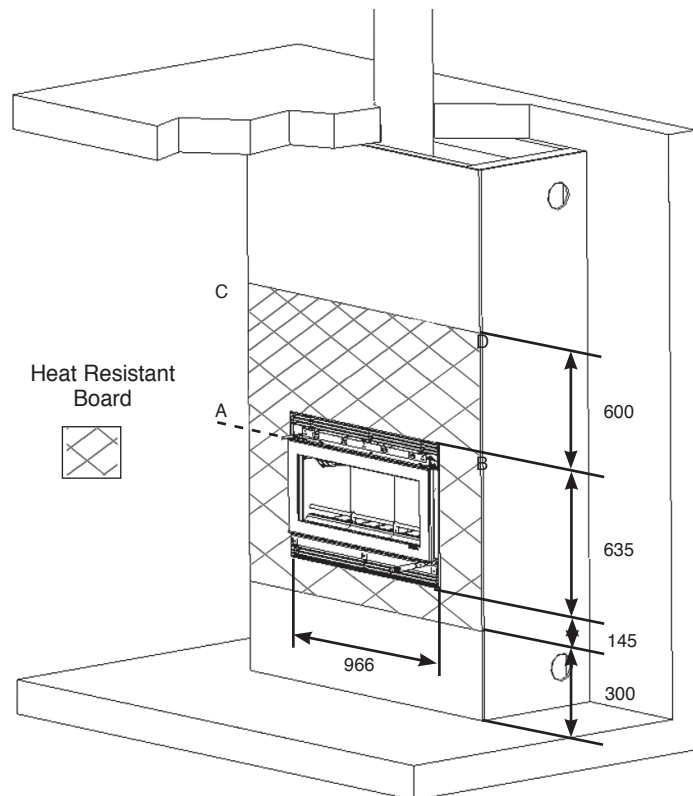

**Note: Heat Resistant Board must be a minimum of 12mm.**

**Extend the heat resistant board 269mm either side of the firebox when installing the appliance to into a wall.**

Fill the gaps between the boards with a joint compound.

**IMPORTANT** - Allow to dry before further plastering as shrinkage will occur. Use multiple thinner coats of joint compound and allow to dry thoroughly between coats. Once level then tape can be used. Cracking at joints can occur if the joint compound is not given sufficient time to dry.

Plaster with a thin coat of plaster of less than 5mm (recommended).

After finishing the wall introduce heat gradually to slowly dry any excess moisture.

Allow to dry again before painting. Process duration: Several weeks

# Installation Instructions - Fitting the 25XS Steel Frame

## ATTACH FRAME BRACKETS

Attach the 3 top brackets Studio frame fixing brackets to the fire.

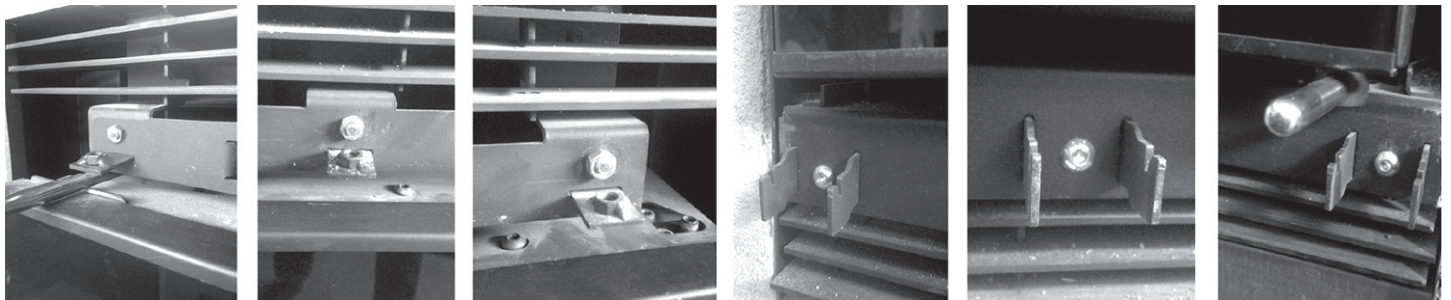
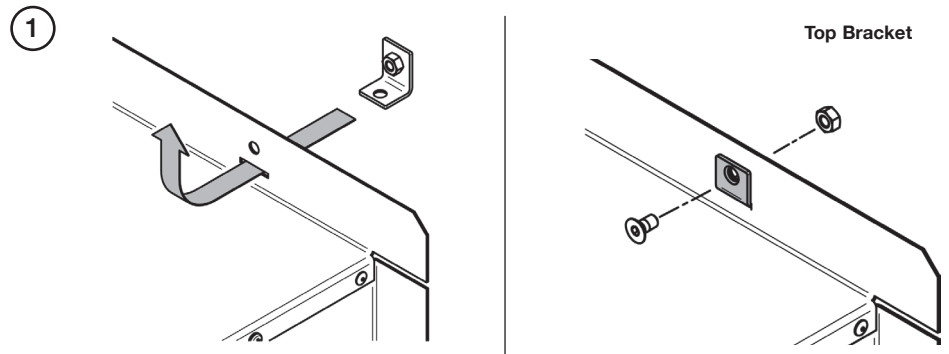

Top LHS Bracket

Top Middle Bracket

Top RHS Bracket

Bottom LHS Bracket

Bottom Middle Bracket

Bottom RHS Bracket

Attach the 3 bottom Studio frame fixing brackets to the fire.

Note: The decorative 25XS Steel frame should only be fitted after the appliance has been fully installed and wall cladding is completed.

Position frame in place on bottom 3 brackets. Rotate the frame into the top of the firebox till frame brackets and top brackets on the firebox, align.

Attach bottom grub screw from the underside of the frame.

Align the frame top brackets and the firebox top brackets to enable Grub screw to be screwed in place firmly: This requires a 4mm Allen Key.

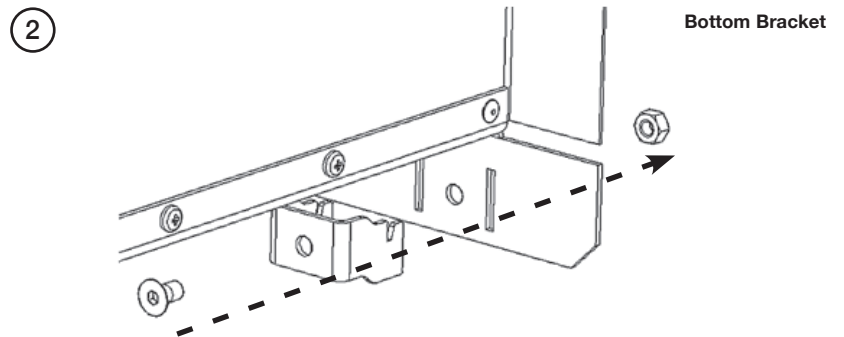

Back of 25XS Steel Frame



Fitting 25XS Steel Frame



Front of 25XS Steel Frame

# Technical Appendix - Technical Appendix

## LEGAL REQUIREMENTS

Before installation and/or use of this appliance please read these instructions carefully to ensure that all requirements are fully understood.

The appliance must be fitted by a registered installer\*, or approved by your local building control officer.

It is very important to understand the requirements of the national Building Regulations and standards, along with any local regulations and working practices that may apply. Should any conflict occur between these instructions and these regulations then the regulations must apply.

Your local Building Control Office can advise regarding the requirements of the regulations.

Works must be carried out with care to meet the requirements of Health and Safety and comply with the Health and Safety rules, and any new regulations introduced during the lifetime of these instructions. Particular attention should be drawn to:

—Handling: The appliance is heavy. Adequate facilities must be available for loading, unloading and on site handling.

—Fire Cement: Some fire cement is caustic and must not come into contact with the skin. Protective gloves must be worn. Wash hands thoroughly with plenty of water after contact with skin.

—Asbestos: This appliance contains no asbestos. If there is the possibility of disturbing any asbestos in the course of installation seek specialist guidance and use appropriate equipment.

—Metal Parts: Take care when installing or servicing the stove to avoid personal injury.

A faulty installation can cause danger to the inhabitants and structure of the building.

For users of this appliance:

Your building insurance company may require you to inform them that a new heating appliance has been installed on your property. Check that your cover is still valid after installing the appliance.



**\*Installation is to be completed by a certified Solid Fuel Appliance Installation Technician (SFAIT) as required by the New Zealand Home Heating Association (NZHHA) conforming to AS/NZ 2918:2001.**



# Technical Appendix - Technical Appendix

## FLUE OUTLET POSITIONS

THE FLUE TERMINATION POSITIONS ARE THE MINIMUM REQUIRED AS PER NZS 2918:2001. IT IS POSSIBLE THAT FLUE HEIGHTS MAY NEED TO BE INCREASED AS A RESULT OF CONFLICTING AIR PRESSURE ENVELOPES THAT MAY DEVELOP OVER SOME ROOFLINE SHAPES AND SURROUNDING OBSTRUCTIONS. RESTRICTION INTO CLEAR AIR MOVEMENT OVER ANY ROOF MAY ALSO REQUIRE DIFFERENT COWL DESIGNS, PARTICULARLY FOR HIGH WIND ZONES OR VARYING LOCAL ENVIRONMENT CONDITIONS.

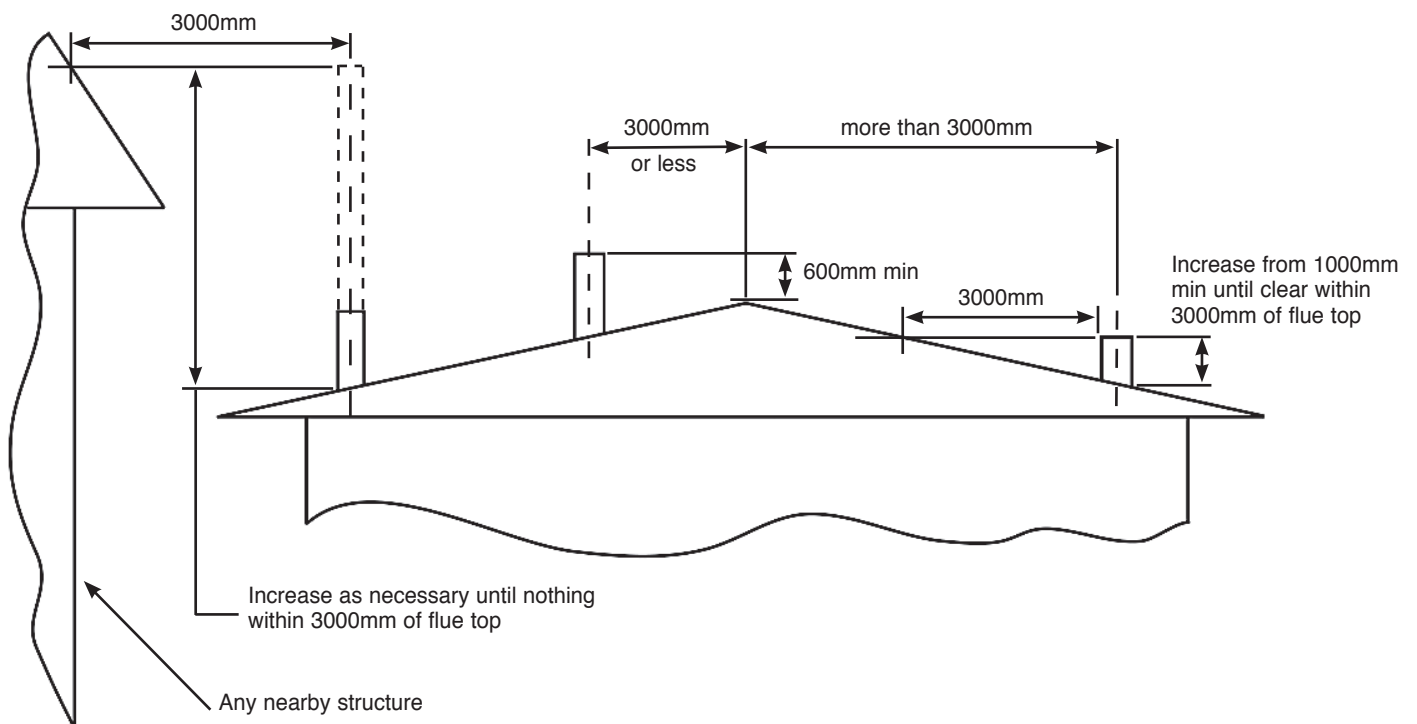
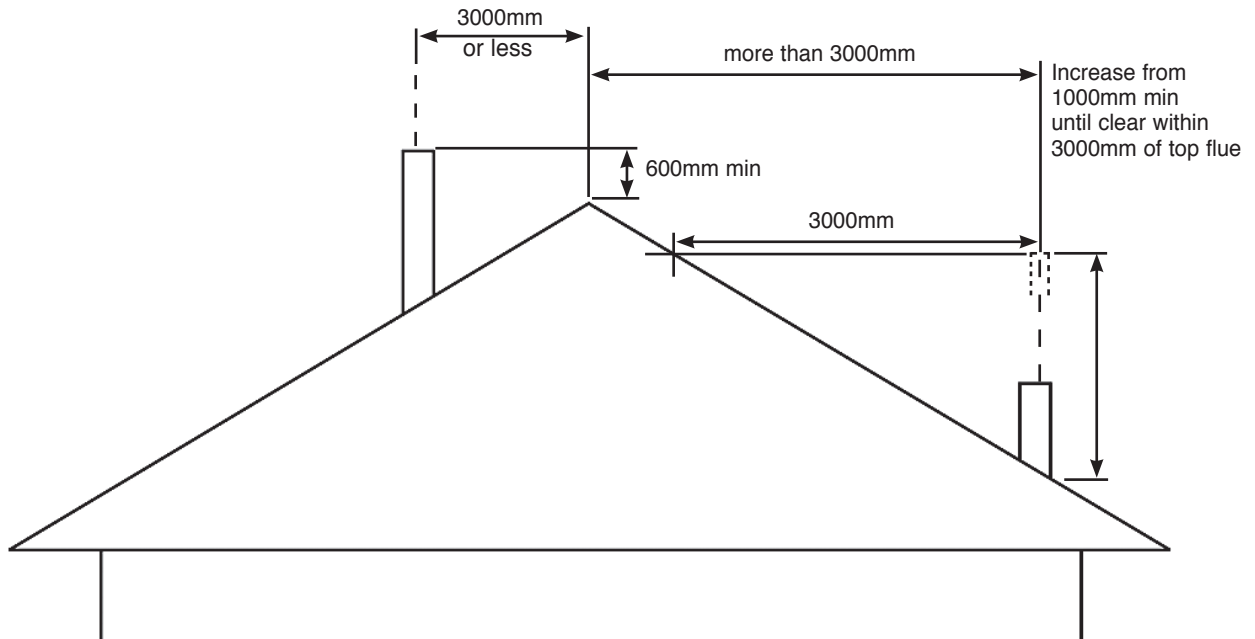

**A HANDY RULE OF THUMB :**  
 Terminate all flues a minimum of 600mm above the highest ridgeline of the donor building.

# Technical Appendix - Flues

## MINIMUM DIMENSIONS - FLOOR PROTECTOR

Also see Page 6 for dimensions.

The appliance must stand on a non-combustible constructional floor protector which is at least 12mm thick with the minimum dimensions as shown in the diagram.

A non combustibile constructional floor protector which is at least 12mm thick and positioned as shown on Page 6. Any elevated or cantilevered floor protector must extend the minimum of 300mm from the door opening and a minimum of 200mm each side of the fireplace opening.

The building must have a suitable load-bearing capacity for the floor protector and appliance. Consult a structural technician for advice before proceeding.

When fitting into an existing floor protector check that the floor protector complies with current construction regulations and is at least the minimum sizes shown.

## FLUES AND CHIMNEYS

**WARNING: THE APPLIANCE AND FLUE-SYSTEM SHALL BE INSTALLED IN ACCORDANCE WITH AS/NZS 2918 AND THE APPROPRIATE REQUIREMENTS OF THE RELEVANT BUILDING CODE OR CODES.**

**WARNING: APPLIANCES INSTALLED IN ACCORDANCE WITH THIS STANDARD SHALL COMPLY WITH THE REQUIREMENTS OF AS/NZS 4013 WHERE REQUIRED BY THE REGULATORY AUTHORITY, I.E. THE APPLIANCE SHALL BE IDENTIFIABLE BY A COMPLIANCE PLATE WITH THE MARKING 'TESTED TO AS/NZS 4013'.**

**ANY MODIFICATION OF THE APPLIANCE THAT HAS NOT BEEN APPROVED IN WRITING BY THE TESTING AUTHORITY IS CONSIDERED TO BE IN BREACH OF THE APPROVAL GRANTED FOR COMPLIANCE WITH AS/NZS 4013.**

**CAUTION: MIXING OF APPLIANCE OR FLUE-SYSTEM COMPONENTS FROM DIFFERENT SOURCES OR MODIFYING THE DIMENSIONAL SPECIFICATION OF COMPONENTS MAY RESULT IN HAZARDOUS CONDITIONS. WHERE SUCH ACTION IS CONSIDERED, THE MANUFACTURER SHOULD BE CONSULTED IN THE FIRST INSTANCE.**

The flue or chimney system must be in good condition.  
It must be inspected by a competent person and passed for use with the appliance before installation.

Products of combustion entering the room can cause serious health risks.

The following must be adhered to:

AS/NZ 2918:2001:4.9.1

- a) The flue pipe shall extend not less than 4.6m above the top floor protector.
- b) The minimum height of the flue system within 3m distance from the highest point of the roof shall be 600mm above that point.
- c) The minimum height of a flue system further than 3m from the highest point of the roof shall be "a minimum" 1000mm above roof penetration.
- d) No part of any building lies in or above a circular area described by a horizontal radius of 3m about the flue system exit.



**A HANDY RULE OF THUMB :**  
Terminate all flues a minimum of 600mm above the highest ridgeline of the donor building.

**N.B. in extreme wind areas it may be necessary to consult your local agent for further technical assistance.**

— If flue is concealed in a chase, allow for air vents (2 x 80mm diam. or equivalent) at the highest possible point on the chimney chase or alternatively, allow a min 25mm air space between the casing cover spigot and the outer casing, see Figures 1.1, 1.2 and 1.3.

# Technical Appendix - Flues

**External Requirements**

Refer to AS/NZ 2918:2001;4.9.1

**Air Ventilation Through Chimney Chase**

Fig 1.1

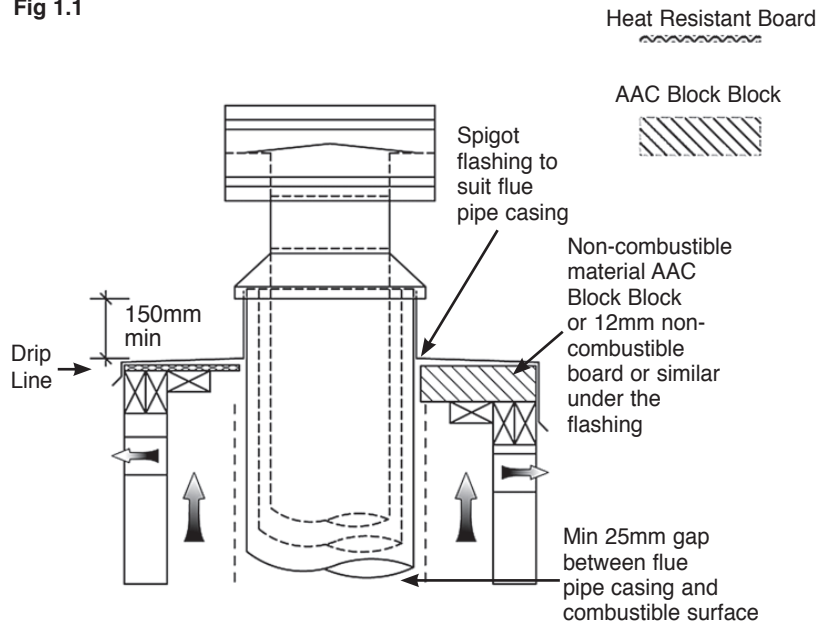

**Air Vent**

Minimum 2 x 80mm diameter or equal square or rectangle shaped area

**Air Ventilation Through Top Flashing**

Fig 1.2

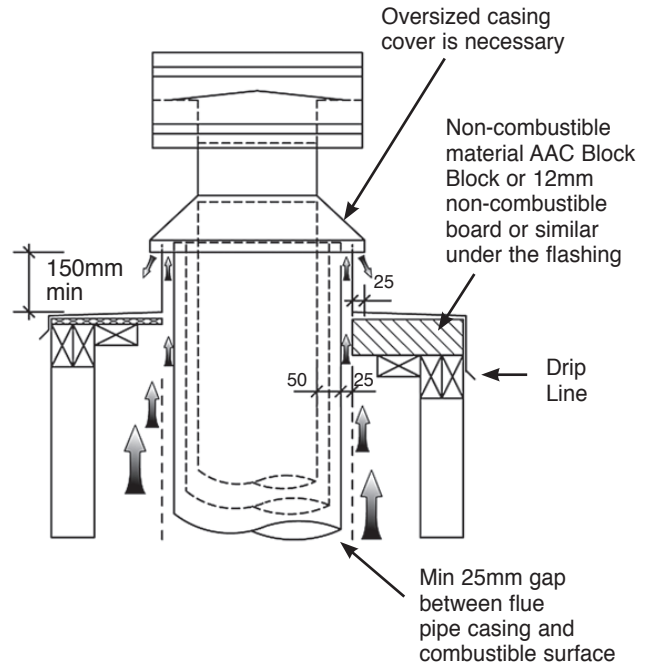

**The flue system and its installation must comply with AS/NZS2918:2001**

Fig 1.3

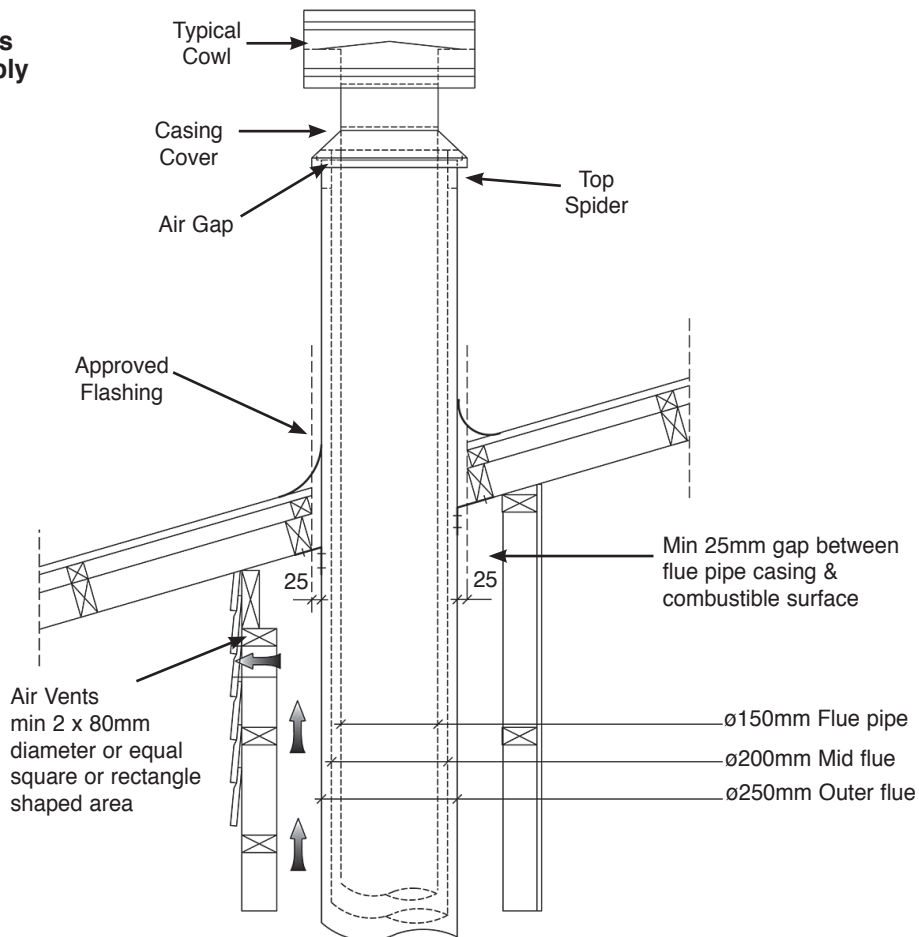

**Note:** All external air vents & ceiling penetrations must be bird & rodent proofed with permanently fixed screens

## CAVITY VENTILATION

### CAVITY VENTILATION OPTIONS

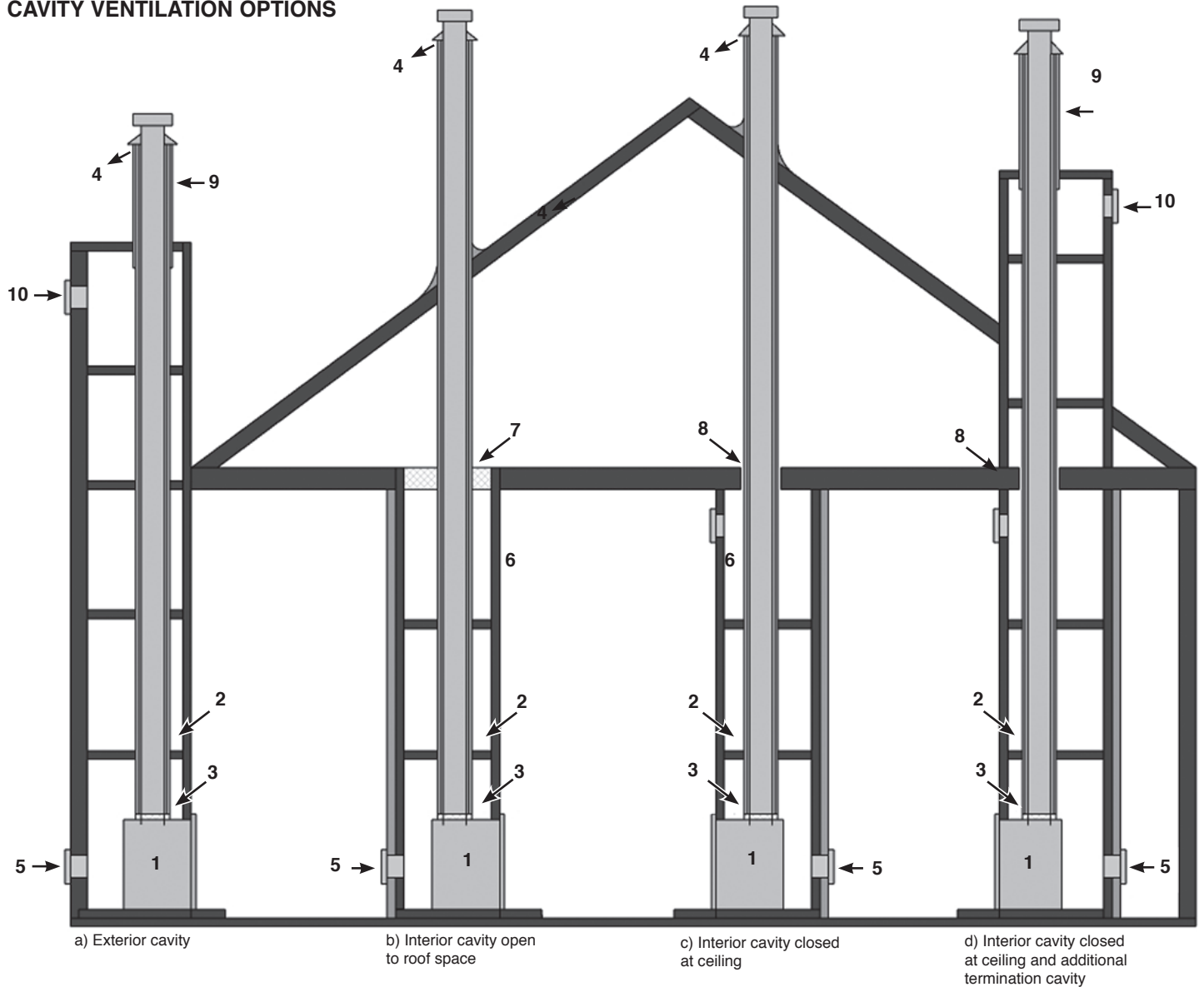

#### LEGEND

1. Appliance
2. Vented flue system with 2 casings
3. Flue system air inlet
4. Flue system air outlet
5. Bottom vent –cool air inlet
6. Room vent –interior hot air outlet
7. Ceiling vent –vermin proof mesh
8. Vented ceiling penetration
9. Venting through casing
10. Top side vent to built-in structure

# Technical Appendix - Ventilation

## AIR REPLACEMENT VENTILATION

Increase air supply provisions where a room contains multiple appliances. Internal air pressure balance can be critical

If vents open into adjoining rooms or spaces there must be an air vent of at least the same size direct to the outside.

For REPLACEMENT AIR site the vents where cold draughts is unlikely to cause discomfort. This can be avoided by placing the vents near or close to the appliance and located as close to floor level as possible.

Additional ventilation is required. This must be provided using a permanently open air vent, of the size listed, which is positioned so that it is not liable to be blocked both inside and outside the building.

Minimum recommended air replacement is 2 x 175mm x 175mm or equivalent

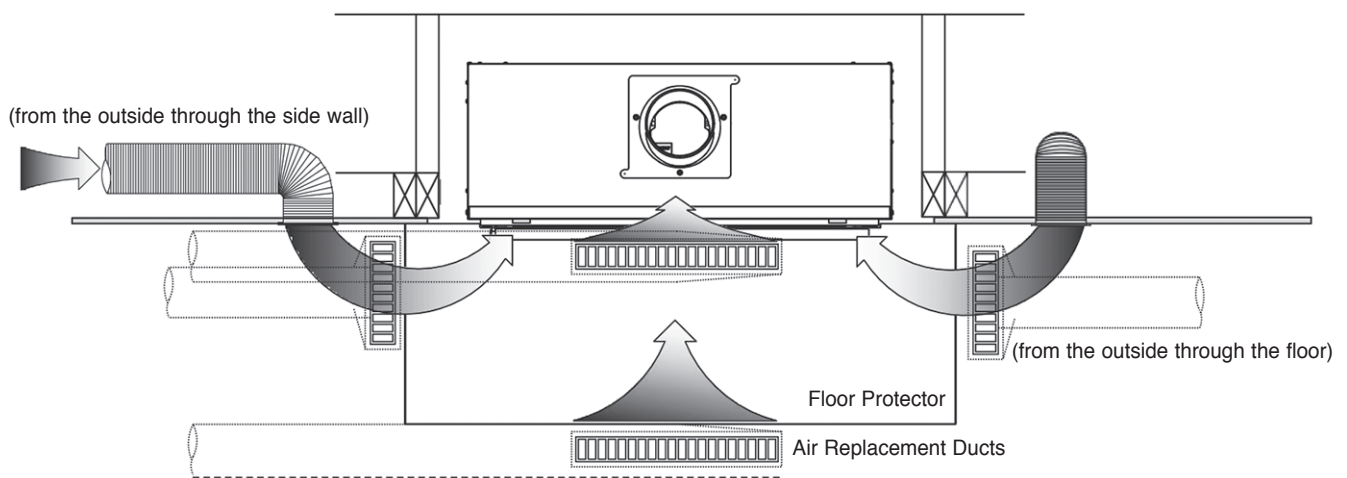

- i** Allowances **MUST** be made for air replacement vents to be located near the fireplace to aid combustion.  
A minimum of one pair of air vents is recommended or one large vent.  
Allowance is to be made for a minimum of 2 inlet ducts from outside to internal vent location.  
Note: **DO NOT USE FIREPLACE CAVITY VENTILATION AS A METHOD OF AIR REPLACEMENT.**







Head Office & Showroom  
12 Tawari Street  
Mt Eden, Auckland, New Zealand  
+649 623 6990  
thefireplace.co.nz



Manufactured by:

**Stovax Ltd, Falcon Road, Sowton Industrial Estate, Exeter, Devon, England EX2 7LF**  
**Tel: (01392) 474011 Fax: (01392) 219932 E-mail: info@stovax.com www.stovax.com**

**E & O E**

Adapted from English Issue 7

