

Wood Fire Installation & Owner's Operation Manual



metrofires

Insert Wood Fires

Important information.....	2	Getting to know your Metro fire.....	10
Assembling your Metro fire.....	2	Operating your Metro fire.....	10
Floor protector	5	Cleaning and maintenance	11
Installing your Metro.....	6	Troubleshooting	13
Wetback installation	7	Metro Fires warranty	14
Important operation information	9	Replacement parts	15

WARNING! Important Information

- **WE HIGHLY RECOMMEND YOU READ THIS ENTIRE MANUAL AS INCORRECT OPERATION, MISUSE AND/OR LACK OF MAINTENANCE WILL VOID THE WARRANTY**
- The appliance and flue-system shall be installed in accordance with AS/NZS2918 and the appropriate requirements of the relevant building code or codes
- Any modification of the appliance that has not been approved in writing by the testing authority is considered to be in breach of the approval granted for compliance with AS/NZS4013 and will void the warranty
- The appliance must be installed correctly. We recommend a competent and suitably qualified NZHHA installer

Metro insert fires are tested to comply with AS/NZS 2918 incorporating Appendix 'E' when installed in accordance with this manual. Ensure you are fully conversant with the relevant standard and contents of this manual.

Please take particular note of the following:

- Your Metro should be installed with a Metro ECO flue system which has been developed to enhance the performance of Metro fires. A minimum length of 4.1 metres of 150mm diameter is required. Any alternative flue system must have a minimum flue pipe length of 4.1 metres of 150mm diameter flue pipe & have been tested to AS/NZS 2918
- All flue joints must be sealed and riveted in three points with stainless steel or monel rivets; the bottom of the flue in particular **MUST** be fully sealed into the flue outlet of the Metro wood fire and secured with the bolt & nut as supplied in the component kit
- The 150mm flue pipe must be fully encased to the underneath of the flashing cone, from above the chimney breast (there must not be any 150mm flue pipe exposed)

CAUTION! Important Information

- Correct installation is critical to the safe operation and performance of this wood fire.
- Mixing of appliance or flue-system components from different sources or modifying the dimensional specification or components may result in hazardous conditions. Where such action is considered, the manufacturer should be consulted in the first instance
- Do not install a Metro fire if there is any sign of visible damage to the product
- This appliance must be regularly maintained.
- Use authorised Metro replacement parts only. The use of unauthorised parts may void the warranty
- This manual **MUST** be left with the home owner

- Ensure a suitably rated high temperature insulation is placed between the outer cabinet and the masonry to prevent air from within the room being drawn into the chimney cavity. Optimum convective heat output is achieved when the cabinet top is lifted to its maximum height and the firebox cabinet is correctly insulated within the cavity
- In New Zealand, the Metro Insert must be bolted securely to the base of the chimney cavity to comply with the seismic restraint provisions of AS/NZS 2918
- The Trend and Smart fascias are available in both vitreous enamel and metallic black high temperature paint finish. Take care during assembly and when lifting and fitting the fascia that you do not damage the vitreous enamel coating. Any surface damage to the paint finish fascias can be repaired with the use of Pioneer high temperature paint
- **DO NOT** lift the Insert fascia with your fingers under the louvre's.

Assembling your Metro fire

All Metro Insert wood fires are packed in two heavy-duty cartons. The Insert firebox is supplied in a heavy duty palletised carton, this carton is clearly labelled. The fascia and door are packaged inside a smaller separate carton. This carton is also clearly labelled to show the colour and coating finish of the fascia and door. Metro fascias are coated in either vitreous enamel or high temperature paint. Having removed the packaging and located this manual, familiarise yourself with the diagrams on pages 3 & 4, and proceed as detailed.

Note: The Metro carton shows the model Metro you are about to install, enabling you to select the appropriate model's assembly instructions.

Pre-installation - Firebox cavity

Prior to installing your Metro Insert firebox into a fireplace cavity, it is important that specified clearances and other requirements are complied with as follows:

- The chimney must be swept and checked for cracks and general overall condition. If repairs are necessary, they must be carried out by a suitably qualified person

- Check the cavity dimensions to ensure the fireplace insert will fit. It is usually necessary to remove fire bricks from the lower fireplace cavity
- The base of the fireplace cavity on which the Metro fireplace insert will rest must be level. If it is not, it should be levelled using mortar
- If an ash removal door exists in the base of the fireplace cavity it should be sealed shut to prevent air entering the cavity
- If a timber or combustible mantel shelf exists above the fireplace Insert opening, it should be a minimum distance above the top of the Metro's fascia. If less than the minimum specified, a heat shield will be required to be fitted under the mantelshelf using the relevant detail as set out in AS/NZS 2918. Mantle clearances are detailed on page 5.

ECO Insert Fan (Trend Insert model only)

In all clean air zones, the Metro Trend Insert must be installed with Metro's ECO Insert fan which is a single speed, thermostatically controlled device. This fan must be permanently wired and therefore requires the services of a registered electrician. Fitting instructions for the fan are supplied with the fan module.

Assembling your Metro fire

Metro Insert firebox

- Remove from within the firebox the plastic bag containing the bolt kit, two firebricks wrapped in a cardboard wrapper and then the top baffle assembly
- A 'spacer' washer has been pre-fitted and taped to the top door hinge pin on the left hand side of the firebox (Refer Inset A) remove this tape
- Remove the 'cabinet top' which is packed inverted on top of the firebox and fit it into position over the cabinet sides as detailed in Diagram 1. Ensure the rear edge is fitted correctly as shown Diagram 1, Inset 'B', the rear edge of the cabinet top must fit into the slot provided. Lift the front to the highest available position and using two of the self tapping screws from the plastic bag, secure the cabinet top in place taking care to not damage the insulation blanket.

Note: This panel can be fitted at two height's. If the height of the fireplace opening will allow, fit the cabinet top in the higher position, fit screws from inside the cabinet facing out.

- Ensure the insulating blanket is in position on the top of the cabinet and remains in a sound condition
- Remove the four speed clip nuts from the plastic bag and fit them to the holes provided in the front edge of the cabinet as shown in Diagrams 1 and 1A
- Next you need to fit the top baffle.

All insert models feature a two piece top baffle which locates onto six lugs provided on the side walls of the firebox's upper chamber, as detailed in Diagram 2 on page 4. The rear baffle section is 6mm folded steel and has a central locating pin fitted to its front top surface. Fit this rear baffle through the door opening and into position in the upper chamber of the firebox. It is supported on the rear four support lugs and must be hard back against the rear wall of the firebox with the central locating pin facing up and towards the front.

Next, locate the front baffle which is a combination baffle comprising of a 6mm steel plate with a promet (white board) front extension. Fit this baffle through the door opening and into position, ensuring the hole provided on its rear edge is positioned over the locating pin fitted to the rear baffle.

Unwrap the two firebricks from the cardboard wrapper and fit the side bricks to each side of the firebox. Location lugs are fitted to the base and rear of the firebox to retain the side bricks in position, refer to the relevant Diagram 2 on page 4.

Assemble the air slide located in the firebox to the primary air inlet. First remove the bolts and spacer washers and re-install with the air slide in place with the air control tab to the right hand side. Ensure the stepped washers are inside the slots provided and tighten the bolts. Check the slide moves freely left to right before proceeding.

Diagram 1 - ECO Insert Firebox

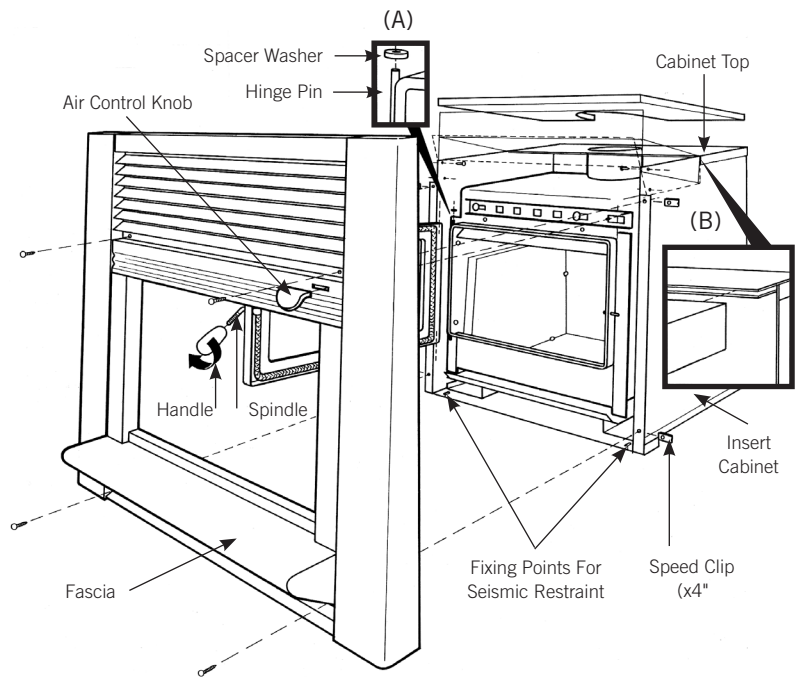
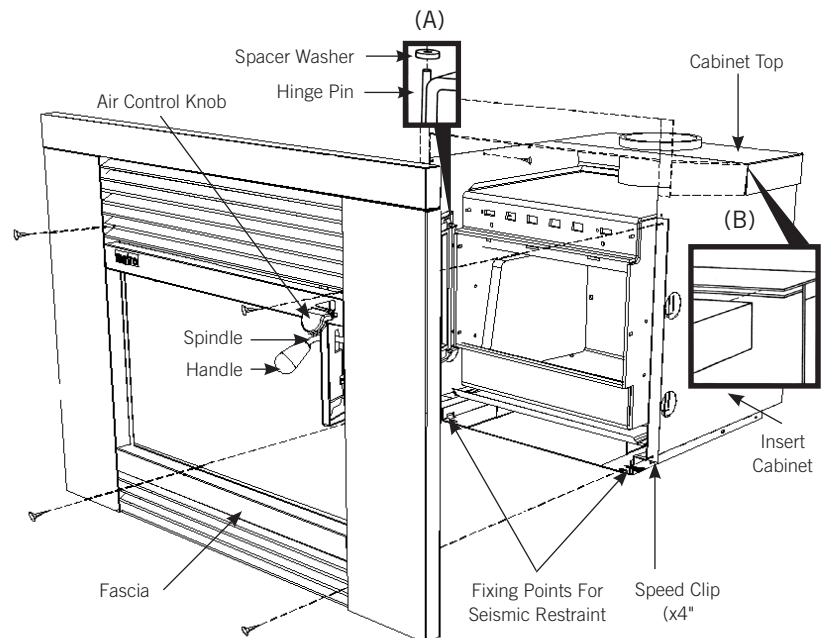
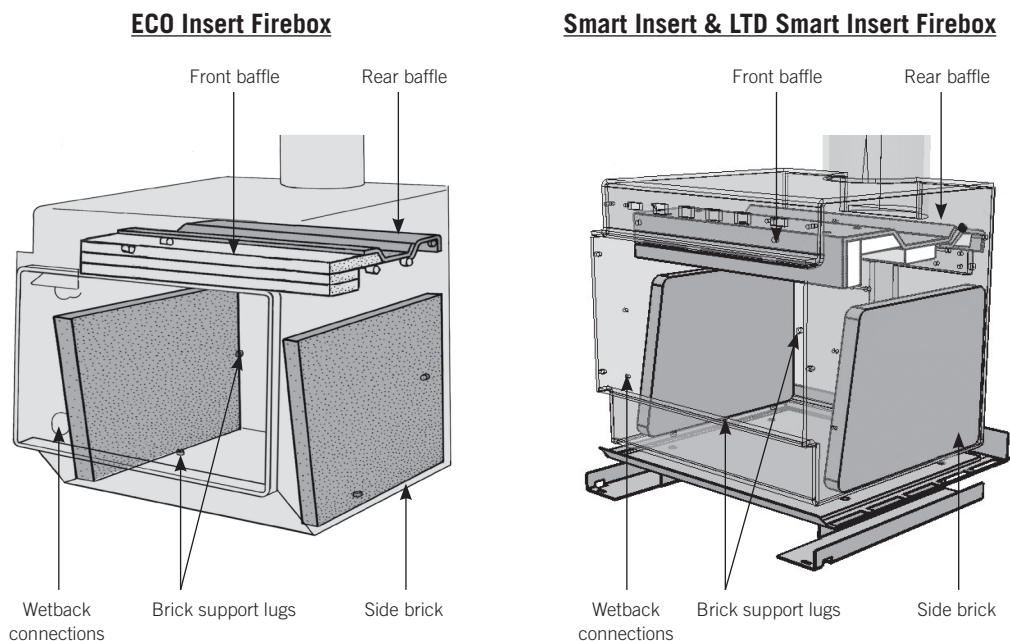

Diagram 1A - Smart Insert & LTD Smart Insert Firebox



Assembling your Metro fire

Diagram 2 - Firebox brick and baffle locations



Assembling the fascia (Trend Insert model only)

The Trend Insert fascia is supplied partly assembled, and requires the ashlip and bottom louvre to be fitted as illustrated in Diagrams 3 and 3A below. To assemble, proceed as follows: -

- On a large flat, clean and soft surface (carpet floor) slide the fascia out of the carton, front face down and remove the door which is packed into a separate carton located in the centre of the fascia. Close the flaps of the fascia carton and lay the fascia front down on top of this now empty carton
- Remove the two sections of tape securing the ashlip panel to the rear face of the fascia as detailed in Diagram 3. Carefully lift the ashlip panel away from the fascia and place it gently to one side
- Remove the four screw's and bottom louvre as illustrated in Diagram 3.

- Reposition the ashlip into its final position as illustrated in Diagram 3A taking particular attention to ensure:
 - The ashlip is the right way around
 - Do not mark the coating on the ends of the ashlip panel as you slide it into the fascia, you may need to slightly prise apart the fascia side panels as you fit the ashlip.
- Position the bottom louvre as illustrated in Diagram 3A and refit the four screws previously removed.

The fascia is now completely assembled and ready for installation. When moving the fascia, hold it at both sides to avoid 'twisting' the fascia which may cause the enamel to chip.

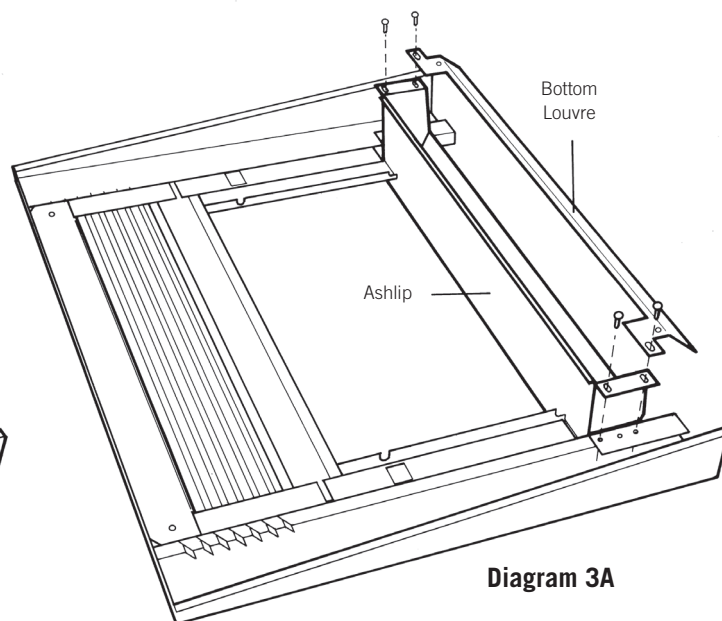
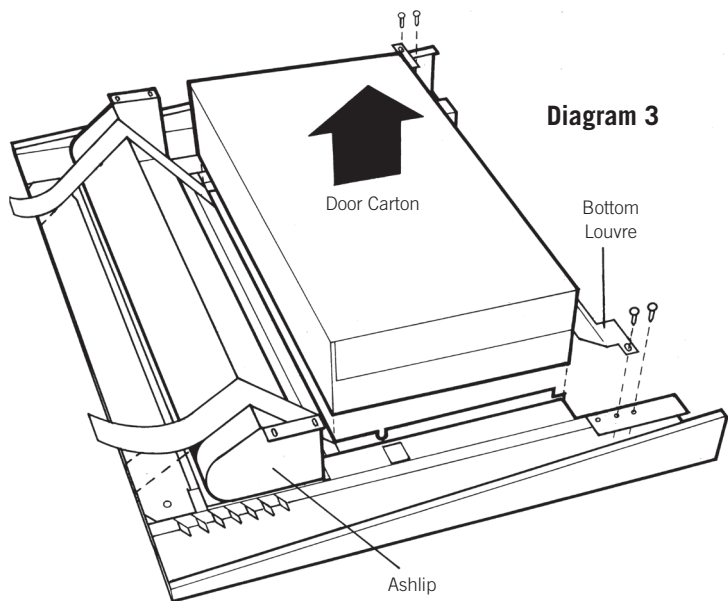

Floor protector requirements

Floor protector requirements

Metro fireplace inserts are designed to be installed directly onto a concrete base. The floor protector is required to project in front of the Metro and must extend a minimum of 200mm to each side of the door opening making the minimum floor protector width 825mm.

For aesthetic reasons the *recommended* floor protector width for both Smart Insert models is 890mm due to the fascia width of these models.

The floor protector must project from behind the fascia the distance specified (I) in the table below. Minimum projection is the distance from the front of the wall lining (behind the fascia) to the front non combustible point of the floor protector.

Trend Insert

On properties less than 2 hectares, the Trend Insert must be installed with the single speed Metro thermo fan.

The Trend Insert requires an ash-hearth floor protector with recommended construction of tiles on 6mm thick non combustible board. The minimum floor protector projection forward of the Metro is 300mm as detailed in the table below. Any non-combustible material fixed directly to a combustible floor is acceptable.

Smart Insert

The ECO Smart Insert requires an insulating floor protector with recommended construction of tiles on 26mm thick eterpan or alternative insulating material of equivalent insulation properties. The forward projection detailed below (I) is dependent on the height of the fireplace insert above the combustible floor.

LTD Smart Insert

The LTD Smart Insert requires an insulating floor protector with recommended construction of tiles on 26mm thick eterpan or alternative insulating material of equivalent insulation properties. The forward projection detailed below (I) is dependent on the height of the fireplace insert above the combustible floor.

Mantel clearance

A timber or combustible mantel shelf above the fireplace Insert opening should be a minimum distance (L) above the top of the Metro's fascia as detailed in the table below. If the clearance is less than the minimum specified, a heat shield will be required to be fitted under the mantelshelf using the relevant detail as set out in AS/NZS 2918:2001.

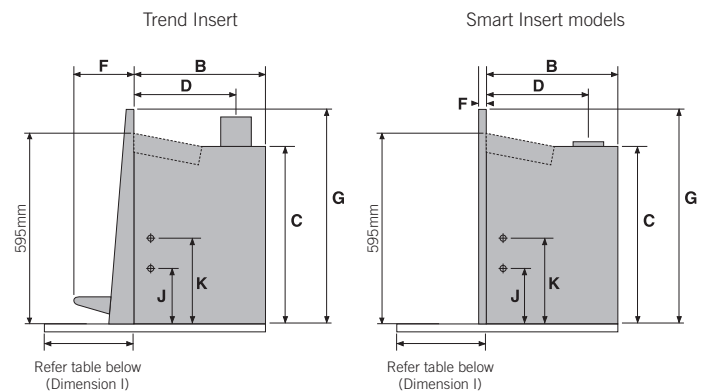

	Firebox Width	Firebox Depth	Firebox Height	Flue Centre	Fascia Width	Fascia Depth	Fascia Height	Minimum Floor Protector Width	Minimum Floor Protector Projection	Wetback In	Wetback Out	Mantel clearance
Insert & Built-In Dimensions (mm)	A	B	C	D	E	F	G	H	I	J	K	L
Trend Insert	560	500	550	405	810	185	650	825	300	170	360	340
Smart Insert	560	495	550	405	890	30	672	890	312	130	325	475
LTD Smart Insert	560	495	550	405	890	30	672	890	312	130	325	475

Please note: All measurements detailed above exclude the 13mm insulating blanket.

Floor Protector Heights	0mm	10mm	15mm	20mm	25mm	30mm	35mm	40mm	41mm+
Trend Insert - DIMENSION I	300mm minimum projection is required irrespective of the height of the floor protector								
Smart Insert - DIMENSION I	395mm	371mm	371mm	353mm	353mm	332mm	332mm	312mm	312mm
LTD Smart Insert - DIMENSION I	395mm	371mm	371mm	353mm	353mm	332mm	332mm	312mm	312mm

Installation

Position the Metro Insert firebox which is still attached to its wooden pallet directly in front of the fireplace cavity with the rear of the insert facing the fireplace opening. The fireplace insert assembly is bolted to the wooden pallet through its base panel at two points being each front corner. Remove both screws and slide the insert into the fireplace cavity taking care not to mark the floor protector. Discard the pallet.

1. Attach the fascia with the four longer screws that were supplied in the plastic bag, taking care that the air control lever passes through the slot provided in the fascia. Centralise and level the fascia on the fireplace insert door and secure the four screws.
2. Applying pressure to the fireplace firebox (not the fascia) carefully manoeuvre the Metro until the rear of the fascia is just touching the front face of the fireplace surround. Taking care not to move the fireplace insert, remove the fascia and mark the position of the fireplace insert onto the fireplace base.
3. Using a masonry drill, drill into the chimney base through the two slots which the fireplace insert was secured to the pallet through. Check to ensure the fireplace insert hasn't moved and secure using suitable masonry anchors to comply with the seismic restraint provisions of the standard.
4. Check that the flue stub of the fireplace insert is in line by looking down the chimney, if not a stainless steel offset or flexi flue will be required.
5. Following the instruction sheet supplied with the flue system, proceed and fit the flue with ALL JOINTS SEALED and riveted with a minimum of three stainless steel or monel rivets on each joint.
6. With the flue pipe in position and sealed with a high temperature fire cement into the flue stub, drill through the hole provided in the front of the flue stub into the stainless steel flue pipe and secure with the 6mm bolt and nut supplied in the plastic bag.
7. Refit the top baffle into the firebox's upper chamber. Support by the steel plates only and keep the baffle horizontal.
8. Ensure the cabinet top front panel is installed and fitted correctly to the rear mating section. This panel must be lifted to either its maximum height or the maximum height allowable with the chimney cavity and fixed in place. The white insulation blanket must also remain in place and intact surrounding the insert cabinet.

9. Using a suitably rated high temperature insulation, pack any gap that exists between the sides and top of the fireplace insert cabinet and fireplace cavity walls as indicated in Diagram 4 below. This is to seal off the natural draw of the masonry chimney. Optimum convective heat output is achieved when the cabinet top is lifted to its maximum height and the firebox cabinet is correctly insulated within the cavity.
10. If installing into a clean air zone, the Metro ECO Insert firebox must be installed with Metro's ECO Insert fan as detailed on page 2. Installation and wiring of this fan module is necessary prior to fitting the fascia, and full fitting instructions are supplied with the fan module.
11. Take the door you previously removed from the centre of the fascia and unpack it. Taking the door in both hands with the spindle end in your right hand and outer face of the door facing you, attach the door to the firebox as follows: -
 - With the door in a 45 degrees open position, allow the lower hinge pin on the bottom left hand side of the firebox to pass into the hole provided in the bottom of the door frame
 - Lift the door until the top of the door frame passes over the top hinge pin, then align the hole provided on the top face of the door frame and lower it down over the top hinge pin. The top hinge pin washer must remain in place
 - Take the door handle from the plastic bag and screw it onto the door spindle by turning it clockwise
12. Re-attach the fascia, centralise and level with the door and ensure the air control is moving freely and secure all four screws.
13. Locate the air control knob which is included in the plastic bag and carefully work it onto the air control lever. Check operation.

The Metro is now fully installed and ready for operation but it is preferable to defer lighting the fire for a day or two if possible to allow sealant used in the flue pipe joints to air dry. Alternatively it is recommended you burn 2-3 sheets of loosely crumpled newspaper at a time, approx once every hour over a 6-8 hour period.

Diagram 4 - Insulating the cavity correctly

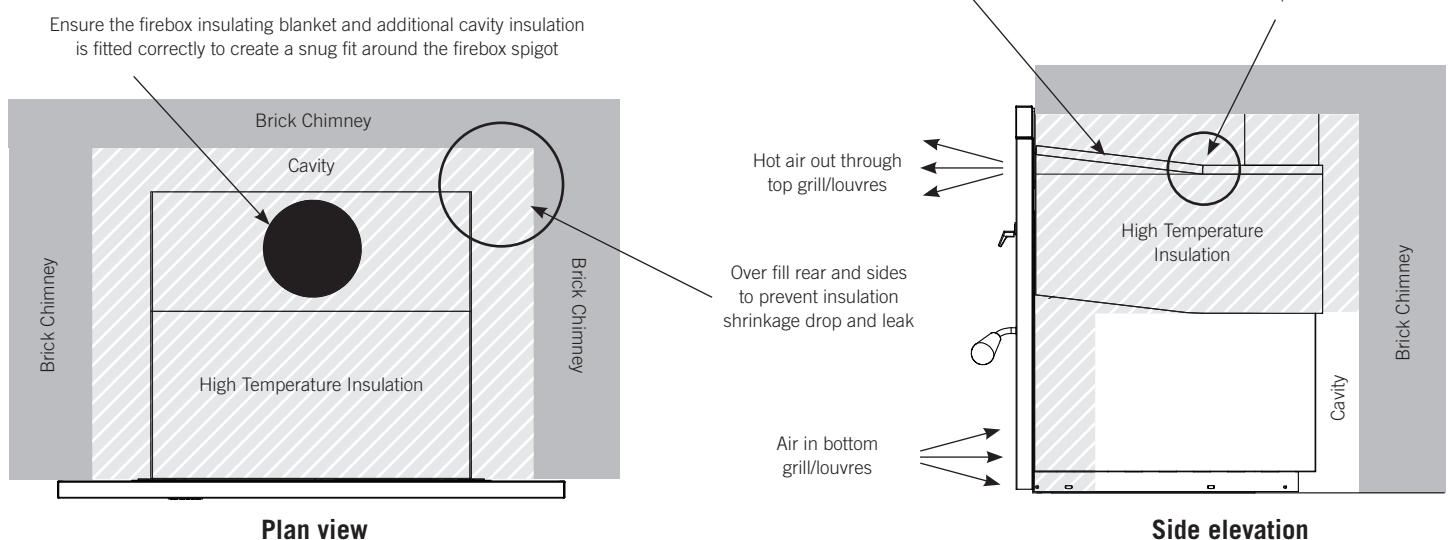

Wetback installation

WARNING! Important Information

- **DO NOT** connect to an unvented hot water system
- Install in accordance with AS 3500.4.1 or NZS 4603 and the appropriate requirements of the relevant building code or codes.

CAUTION! Important Information

- Fitting the wetback is best performed prior to installing the Insert firebox into the fireplace cavity
- Wetbacks must be connected with water before operating the fire and available to the wetback while the fire is in operation
- Wetback systems are not suitable for use in locations where the water supply has lime content. Lime build up inside the coil will eventually block the coil causing the wetback to fail. This is not covered under warranty
- Rainwater collection tanks installed lower than the wetback that use a water pump to supply the home, can cause problems if the pump is not operational. In these situations either the type of wetback or a roof header tank should be considered
- The Metro Trend Insert is not approved with a wetback in a clean air zone but can be installed with either Pioneer's 3kW or 4kW wetback option on properties of 2 hectares or greater.

Water heating is another key feature of your Metro wood fire; nearly all Metro models can be fitted with a wetback, which are designed to give maximum output with minimal effect on the operation of the fire. Only the Pioneer cast jacket wetback system should be fitted to your Metro; alternative wetbacks will void the Metro's emission approvals and may seriously affect the performance of the appliance and void its warranty.

Wetbacks can enable substantial power savings, dependent on the climate in the area in which you live. If you live in a cold climate you are likely to use your Metro for many months of the year, in which case a wetback will reduce or even eliminate your water heating costs over those months. If however you live in a warmer climate and use your Metro for only a few hours a day over the colder months, electricity savings will likely be less.

- Distance from your Metro to the storage cylinder will affect the amount of hot water produced
- Your climate & the manner in which you will 'fire' your Metro will determine the amount of hot water produced.

All Insert model wetbacks can be fitted to either side of the firebox, with the connection pipe heights detailed in the table on page 5.

It is recommended the return pipe has a minimum rise of 1 in 12; performance will reduce as the distance to the storage cylinder increases.

Wetback installation for the Trend Insert



The Metro Trend Insert is not approved with a wetback in a clean air zone but can be installed with either Pioneer's 3kW or 4kW wetback option on properties of 2 hectares or greater.

Pioneer's 3kW and 4kW wetback options are fitted internally to either side of the ECO Insert firebox and LTD Insert firebox.

To fit the 3kW or 4kW wetback proceed as follows

1. Remove the brick from the inside of the firebox from the side the wetback is to be fitted too.
2. Expose the holes in the firebox wall through which the connection pipes will pass.

The ECO Insert fireboxes has 3mm pressed washers covering these two openings and two 6mm bolts which are fitted inside the firebox near the connection holes, remove these also.
3. Using a hole saw or snips, prepare the cabinet for the connection pipes. Note, these holes should be a neat fit or have any excess gap covered or filled with high temperature insulation.
4. Using the tube of sealant supplied with the wetback, apply a liberal bead of sealant around both connection holes on the inside of the firebox. On the rear of the wetback casting apply the remaining contents of the tube equally around both connection pipes and also the outer circumference of the wetback which will face the inside rear wall of the firebox. This will completely seal the wetback to the inside rear wall of the fire on installation.
5. Fit the wetback into the firebox and position the connection pipes through the connection holes in the firebox.
6. Fit two bolts through the slots provided in the wetback, align the wetback so its front edge is parallel to the door opening and secure the bolts.
7. The wetback is now ready for connection to the storage cylinder by a registered plumber.

Wetback	Suitable for models:
Smart Wetback 	<ul style="list-style-type: none"> • Smart Insert • LTD Smart Insert
3kW Wetback 	<ul style="list-style-type: none"> • Trend Insert (properties of 2Ha+ only)
4kW Wetback 	<ul style="list-style-type: none"> • Trend Insert (properties of 2Ha+ only)

Wetback installation

Wetback installation for the Smart Insert & LTD Smart Insert

The Smart Insert water heater comes fully assembled and is designed to be fitted to the outside face of either the left or right hand side of the firebox.

Note: The hot water output of this water heating device is dependent on correct installation and the proximity of the Smart Insert to the hot water storage cylinder.

To fit the Smart Wetback proceed as follows

- The closer the Smart Insert is to the hot water storage cylinder, the greater the hot water production will be, and generally distances over 3 metres are not recommended
 - The return hot water connection copper pipe must be insulated and have a minimum rise of 1 in 12 along its entire length. 1 in 12 is minimum and the greater the rise the better the performance
 - The return hot water pipe must be connected to the riser pipe connection in the base of the hot water storage cylinder.
1. Remove the fascia (if fitted), then on the side of the firebox to which the water heater is to be fitted, remove the angle cover plate from the inside face of the outer cabinet. Also, remove the fire brick on the wetback side from inside the fire box.
 2. Having removed this cover plate the front face of the inner wrap is exposed. Fold the front face of the inner wrap outwards so it is parallel with the outer cabinet. This is needed to create access for the water heater to fit between the firebox and the inner wrap.
 3. Remove the two square knock out plates from the front face of the inner wrap to provide clearance for the two connection pipes when the return is folded back.
 4. Remove the two 50mm diameter knock out plates from the outer cabinet.
 5. With a long handled 10mm set spanner, reach in between the inner wrap and the firebox and loosen the nut on the rear Pozi drive screw which will be used to secure the water heater. Then unscrew from the inside and discard the 6mm nut as the screw will thread directly into the water heater casting. Repeat for the two front bolts but retain the nuts and washers.
 6. Remove the water heater from its box, which also contains a tube of fire cement. You will note a 6mm bolt and washer is fitted to one of the casting ribs, remove this.
 7. Smear a "liberal but even" amount of Pioneer fire cement over the entire 'flat face' of the water heater in order to ensure full surface contact with the outside face of the firebox.
 8. Hold the hot water heater by the two copper pipes and slide the water heater between the inner wrap and the firebox until the pipes are vertical and in line with the two 50mm holes in the outer cabinet. The pipes will be tight against the outer cabinet as you do this, but the cabinet will flex enough to allow you to work the device until the pipes pass through the 2 x 50mm holes in the outer cabinet.
 9. Re-fit one of the bolts previously removed (stage 5) from inside the firebox through one of the two slots provided in the front edge of the water heater casting, and loosely attach the washer and nut to the thread of the bolt.
 10. Next pivot the water heater using the first bolt just refitted as a pivot point, and refit the rear pozi drive screw from inside the firebox into the rear tapped hole in the casting. Then refit the remaining front bolt and attach the washer and nut.
 11. Fully tighten all three fastenings, and check to ensure the casting has pulled up evenly onto the side of the firebox. Excess fire cement should be visible around the entire perimeter of the casting.
 12. Bend the front returns of the inner wrap back into place so it folds around the front of the water heater, then secure the inner wrap to the casting by refitting the 6mm bolt and washer previously removed at stage 6.
 13. The water heater is now ready to have the copper pipe work attached for connection to the hot water storage cylinder (brazed joints are recommended)
 14. Once all joints have been thoroughly checked and tested for leaks, refit the angle cover plate removed at stage 1, then align and refit the fascia. Both side bricks must be fitted inside the firebox.

WARNING! Important Information

• **WE HIGHLY RECOMMEND YOU READ THIS ENTIRE MANUAL AS INCORRECT OPERATION, MISUSE AND/OR LACK OF MAINTENANCE WILL VOID THE WARRANTY**

- Any modification of the appliance that has not been approved in writing by the testing authority is considered as breaching AS/NZS 4013 and will void the warranty
- Do not use flammable liquids or aerosols in the vicinity of this appliance when it is operating
- Do not dry clothes on or near this appliance
- Do not use flammable liquids or aerosols to start or rekindle the fire OR store fuel within the Metro's specified installation clearances
- Never operate your Metro with the door ajar, except on initial start up
- Open the air control fully before opening the Metro's door.

CAUTION! Important Information

- This appliance should be maintained & operated at all times in accordance with this instruction manual
- This appliance should not be operated with cracked door glass, over worn, faulty or missing door seals
- Do not use driftwood, treated or unseasoned (wet) fuel, the use of most types of preservative treated wood as fuel can be hazardous and will damage your appliance
- Burning unseasoned (wet) fuel or incorrect operation on extended low burn cycles will cause excessive creosote to form. Creosote is very corrosive and excessive buildups will result in the flue pipe, flue spigot and upper burn chamber failing. Failure of the appliance and/or flue system due to creosote damage is not covered under warranty. The formation of such is not an appliance issue it is a fuel and operational issue
- This appliance must be regularly maintained and replacement parts must be authorised Metro parts only
- Do not empty ash into a combustible container.

Congratulations on the purchase of your Metro fire

Your Metro fire is designed to give you many years of warmth and service, subject to the following key factors. These key factors, if not adhered to are the major causes of unsafe installation, poor performance and flue blockages and potential product issues.

1. Your Metro fire must be installed correctly. We recommended you have your new fire installed by a NZHHA registered installer or a competent and suitably qualified installer.
2. In New Zealand a building consent is required from your local building authority. The homeowner is responsible for obtaining this consent.
3. It is preferable that Metro fires should be installed with a Metro ECO Flue System for improved heat retention.
4. Properly seasoned (dry) wood is necessary for your fire to operate efficiently. Wood with a high moisture content will result in flue pipe blockages, reduce heat output and create other issues. The only fuel to be used in this fire shall be wood that meets the following criteria.
 - Less than 25% moisture content
 - Has not been treated with preservatives or impregnated with chemicals or glue,
 - Is not chipboard, particle board, or laminated board,
 - Is not painted, stained or oiled
 - Is not driftwood or other salt impregnated wood
 - Coal must not be used as a fuel

Note: Once split, Softwood usually takes a minimum of 12 months to season - Hardwoods can take up to 24 months to season - Wood must be stored in a location that enables air circulation. Unseasoned wood stored in a closed woodshed without air circulation will still remain unseasoned 12 months later.

5. Burning unseasoned (wet) fuel or incorrect operation on extended low burn cycles will cause excessive creosote to form. Creosote is very corrosive and excessive buildups will result in failure of the flue pipe, flue spigot and upper burn chamber. Failure of the appliance and/or flue system due to creosote damage is not covered under warranty. The formation of such is not an appliance issue, it is a fuel and operational issue.

Regular maintenance

- DO NOT operate the fire with over worn, faulty or missing door and glass seals. Door seals harden over time and become over-worn (3-4 year's). This allows air to leak into the fire, causing the appliance to 'over fire'
- DO NOT operate the fire with over worn, faulty or missing bricks, baffle plate, promet extension (white board on the baffle plate)
- DO NOT operate the fire with cracked or broken door glass.

Please note, the above 3 points require regular inspection/maintenance (every time the ash bed is cleaned out, generally 3-5 times a season) and if not maintained will void the firebox warranty. A glowing firebox or lower fluepipe is just one sign you are over firing your appliance. Please ensure you keep your proof of purchase/receipt on any parts you purchase.

Your Metro is covered by a full unconditional 12 month warranty on replacement parts, and a 10 year firebox warranty.

Heat output

Metro Fires advertised peak outputs (kW ratings) are based on the NZHHA Maximum Output test method which is undertaken by independent International Accredited New Zealand (IANZ) testing facilities. IANZ accreditation provides assurance that the independent testing facility operates effective quality processes, providing a professional service through expertise and technical competence that is recognised as world-class.

A specific loading method is used with specific fuel to obtain the results, which includes using dry 150mm x 50mm pine and the appliance being loaded and operated on the high setting for an extended period of time. During this time the appliance is periodically refuelled until the appliance reaches it's peak output.

Note: It is not recommended that the appliance be continually operated at it's peak output as this could increase the chance of damage to the appliance firebox and associated parts.

Getting to know your Metro fire

There is a single air control making your Metro fire easy to adjust. The air control moves from left to right, which is 'low to high'. Slide this control knob gently from right to left until you reach a stop. This is a pre-set 'low' position. Your Metro must not be operated at a lower burn rate than this setting.

Raising the door handle anti-clockwise until the latch releases will open the door. You will note that if you let the door go before it is at 90° to the appliance, it will fall closed. This is a safety feature that ensures the door cannot fall open if it is not latched securely. For the door to remain open, you must open it fully.

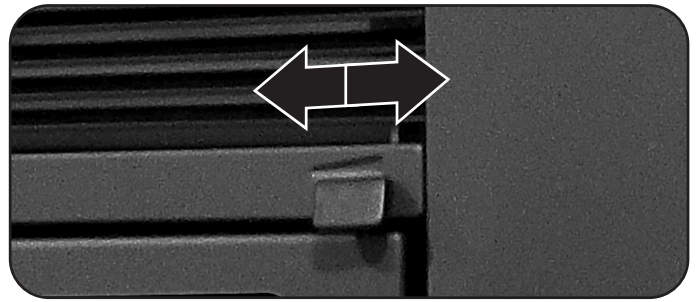

Metro Insert air control

Operating your Metro fire

If your Metro has only been installed within the past few days, the fire cement seal at the base of the flue will not be fully cured. To ensure the cement sets without blistering it is recommended you burn 2-3 sheets of loosely crumpled newspaper at a time, approximately once every hour over a 6-8 hour period.

During the very first fire your Metro will give off an odour and fumes as the firebox paint cures. Do not be alarmed; open all windows and externally opening doors in that room and close any internally opening doors. The fresh paint finish on your wood fire needs to be cured to preserve its quality and the curing process will last for approximately one hour and is likely to happen this one time.

IMPORTANT: Burning a small fire at a medium burn rate for the first few hours of operation will achieve the optimal curing process. Too hot or too cold could present curing issues.

Start up

Place a quantity of loosely crumpled newspaper on the base of the firebox until it is approximately half full of paper, or place firelighters on the base of the firebox. Add dry kindling and move the air control knob fully to the right, being the 'full open' position.

Light the paper at two or three locations across the front of the door opening and leave the door slightly ajar resting on the latch pin if necessary for a few minutes while the fire establishes. Once the kindling is burning well, open the door and add 2-3 small logs at a time until you have a well-established fire. Usually this will take approximately 30 minutes, during which time the air control should be set on 'high' and the door should be closed, except for the initial few minutes and when fuel is being added.

- For optimum performance fuel must be loaded so the logs lay "front to rear" in preference to laying across the width of the firebox. Spaces should be left between the logs to enable oxygen to get to as much of the surface of the fuel as possible
- A small hot fire loaded frequently is more efficient than a large fire burning on a low setting

Normal operation

Once the fire is well established, regulate the air control to achieve the desired burn rate and heat output. As you move the air control to the right, burn rate, firebox temperature and heat output will increase, if you move the control to the left they will decrease. Please note:

- Always open the air control fully prior to opening the door, then open the door slowly. Every time you refuel, leave the air control on 'high' for a minimum of 20-25 minutes to ensure proper combustion
- When loading logs, place them end-on, 'front to back'; air spaces should be left between the logs to enable oxygen to get to as much of the surface of the fuel as possible
- Never use the door to force wood into the firebox, as this is likely to break the glass.

CAUTION! Important Information

If not operated correctly on extended burn cycles, your Metro is likely to incur flue blockages, corrosion of the upper baffle, lower flue pipe and firebox flue spigot. As these are not covered under warranty if they fail through improper use, it is important you operate your Metro correctly.

Extended burning (rural models only)

It is most important if your Metro is to be refuelled and turned down for an extended period, such as an overnight burn that you operate it correctly:

- The wood used as fuel for extended burning **MUST BE FULLY SEASONED (DRY)**. Once the fuel is loaded, the appliance must be operated on high for a period of at least 20 minutes to drive out residual moisture from the fuel (dry wood is usually 20% water content) and ensure surface area combustion.
- **DO NOT** turn the air control down lower than you need to, if you want the Metro to burn overnight, endeavour to obtain an 8 hour burn time, not 12 hours. It will take a few burns to find the correct location of your Metro's air control setting to achieve the length of burn cycle you desire as this setting is affected by several variables including fuel density, flue length and outside wind velocity.
- A smouldering fire over an extended period is likely to deposit corrosive elements into your system which could be detrimental to your Metro.

WARNING! Important Information

- **WE HIGHLY RECOMMEND YOU READ THIS ENTIRE SECTION AS LACK OF MAINTENANCE AND SERVICING PARTS AS REQUIRED MAY VOID THE WARRANTY**
- **THIS APPLIANCE MUST BE REGULARLY MAINTAINED AND OPERATED AT ALL TIMES IN ACCORDANCE WITH THIS INSTRUCTION MANUAL. ALL REPLACEMENT PARTS MUST BE AUTHORISED METRO PARTS ONLY.**

Your Metro fire will give you many years of efficient service with minimal maintenance if operated correctly using dry well seasoned fuel. Your Metro fire must be regularly maintained and any replacement parts must be genuine authorised Metro fires parts only. We recommend using a suitably qualified service agent.

Metro Insert fascias finish

Your Metro Insert fires fascia will be coated with one of two coating systems which can be easily cleaned with a dry soft cloth when the appliance is not in operation. The two alternative coating systems are:

- Vitreous enamel is extremely durable and designed to last the life of the appliance. As vitreous enamel is glass, a solid or heavy object dropped or banged against a panel could chip the enamel so care is required.
- Paint finish wood fires are coated with Pioneer Metallic Black high temperature paint. This coating is not as durable as vitreous enamel and is susceptible to scratching, so care is required. Over time paint finish fires will require periodic repainting to keep them looking their best. Pioneer Metallic Black high temperature paint is the ONLY product suitable for revitalising the paint finish on your Metro fire.

DO NOT use Stove Black, Cast Iron Stove Polish or similar based products to refurbish your paint finished fire.

- The high temperature paint coating is porous to allow for expansion of the product materials and will degrade over time due to the temperatures experience during normal operation
- DO NOT wipe the painted surfaces with anything other than a dry soft cloth. Any ash on the surface when wiping will act as an abrasive to the surface finish
- DO NOT use any abrasive, solvent based or general household cleaners on your appliance as they will damage the surface coating
- Hot coals left on the ashlip, even for a short time, will burn off the painted surface exposing the parent material to oxidation
- Take note that high salt laden air environments (coastal installations) can impact on the appliances surface degradation

Door glass

Providing your fuel is properly seasoned, under normal operating conditions the air-wash design of the Metro's firebox will keep the door glass clear.

If the glass requires cleaning you may use either a razor blade scraper or crumpled wetted newspaper dipped in wood ash rubbed over the glass.

CAUTION! Important Information

- DO NOT operate this appliance with cracked door glass.
- DO NOT operate the fire with over worn, faulty or missing door seals. Door seals will harden over time and allow excess air to leak into the firebox causing the appliance to 'over fire'.
- DO NOT empty or store ashes in a combustible container.
- DO NOT use Stove Black, Cast Iron Stove Polish or similar based products to refurbish your paint finished fire. Pioneer Metallic Black high temperature paint is the ONLY product suitable for revitalising the paint finish on your Metro fire.

- DO NOT use any general household cleaners or solvents to clean the glass on your Metro fire
- If your door glass breaks it must be replaced with 5mm thick ceramic glass which is available from your local Metro retailer
- Never use the door to force wood into the firebox, as this is likely to break the glass.

Door seals

The door and glass seals are something to be mindful of to achieve the optimum performance and heat output from your Metro fire.

A loose fitting door or glass panel are clear signs that the appliance seals need to be addressed. You may also notice that you're burning through more firewood than usual due to the excess air entering the firebox.

Over time, your Metro door rope and glass seals will gradually harden. Usually around 3-4 years, these seals will become hard and cause air to leak into the firebox, causing the appliance to 'over fire'. Your Metro retailer stocks replacement woven fibreglass door and glass seals, which need replacing when they become hard and over worn.

The door of your Metro is easily removed to replace both door and glass seals. Hold the door in both hands and lift the hinge end of the door up and over the top hinge pin, then carefully lower the door from the bottom hinge pin taking care not to damage the ashlip and/or fascia coating.

Fire bricks

Hair-line cracks are not uncommon and are a result of the intense heat within the firebox, coupled with mechanical damage caused by accidental impact when loading fuel. If the fire bricks become cracked to the extent that they start to break up and fall into the fire, they must be replaced.

Door adjustment

Provision is available on both sides of the door for adjustment.

To adjust the hinge end of the door, open the door fully, loosen the top hinge nut and slightly lift the latch end of the door; you will see the hinge assembly move back 1-2mm which will usually be sufficient. Retighten, then repeat by loosening the lower hinge nut, this time applying a slight downwards pressure onto the door to move the lower hinge assembly back a similar distance, then retighten.

The door latch is also adjustable as the latch pin on the right side of the firebox is fitted through a slot. This enables the latch pin to be loosened, moved forward/back and re-tightened to ensure a good tight door seal.

Cleaning and maintenance for your Metro fire - continued

Ash removal

Over a period of time ash will build up in the base of the Metro's firebox and require removal. The time this build-up takes depends on the density and cleanliness of your fuel.

DO NOT operate your fire continuously with a high ash or ember bed as you can damage the firebox rear wall components or increase the likelihood of necessary maintenance.

To remove the excess ash your Metro should not be operating.

- Open the door, and using a hearth shovel or similar, empty the excess ash directly into a steel or non-combustible container. If the ash is not disposed of immediately, be careful where you store it, as the ash can retain heat for many days and become a fire hazard.
- You must leave a bed of ash in the base of the firebox approximately 10mm deep. This insulates the base of the firebox and improves combustion.

Top baffle

This is a 'sacrificial' wear part of the firebox and should be checked monthly. Usually only the promet (white board) front/underneath section needs to be replaced when it starts to disintegrate and fall into the firebox.

To remove and replace your Metro's top baffle, proceed as follows: -

- Fully open the Metro's door and remove the side firebricks carefully. This will give you maximum firebox width to easily remove the baffle
- Reach inside with the palms of your hand face up and extended and lift the top baffle up vertically towards the ceiling of the firebox. You can then pull the baffle assembly forward towards the front of the firebox. This will allow you to then lower the rear of the baffle past the lug supports and lift it out through the door opening. Place it onto a sheet of newspaper or similar to protect the floor protector/coverings
- Your Metro Insert fire has a two piece baffle as illustrated on page 4. The rear baffle section also lifts 'up and out' the same as the front baffle.
- If your Metro Insert fire is fitted with an internal wetback, to remove the baffle you will need to remove the fire brick from the opposite side of the firebox. Then lift the baffle slightly and slide it forward 30mm, allowing the rear edge of the baffle to drop down in front of the rear support lugs on the side of the firebox you have just removed the brick from. The baffle can then be easily removed through the door opening.
- To refit the top baffle. Proceed in the reverse order and note, the baffle must be fitted so its rear is touching the back of the firebox.

Note: Cracks in the promet are not uncommon and have no adverse effect on the operation of your Metro. These cracks are the result of intense heat coupled with expansion and contraction. Burning wood which is not properly seasoned, i.e. 25% moisture content or more, will over time cause the promet to disintegrate and require replacement.

Circulating fan (Trend Insert only)

In all clean air zones, the Metro Trend Insert must be fitted with Metro's ECO Insert fan, This is a single speed, permanently wired and thermostatically controlled device which runs continuously once the firebox reaches operating temperature. This fan is designed to run continually for many years without service, but should be checked monthly to ensure it is operating. If you are in any doubt regarding the fans operation, refer to your Metro retailer or a registered electrician immediately.

Flue systems

Should be checked annually, particularly the bottom end of the lower flue section at its rear lock formed joint. If deterioration is noticed contact your Metro retailer or installer.

The flue pipe should also be swept a minimum of once a year, or as required during the winter season. If smoke enters the room when you open the Metro's door this usually indicates the flue pipe is becoming restricted and needs cleaning. The frequency of flue pipe cleans depends on many factors, with the main variables being:

- The seasoning of the wood. If not properly seasoned you will require frequent flue pipe cleans.
- The density of the wood. Softwoods generally result in more deposits building up in the flue pipe.

To clean the flue pipe of your Metro, proceed as follows:-

- Open the Metro's door fully, reach inside with the palm of your hand face-up and extended, lift the top baffle approximately 20mm, then lift it forward out through the door opening, placing it on a sheet of newspaper you have placed on the front of the floor protector. To prevent jamming, removal and replacement of the top baffle is best performed using both hands.

Note: Some appliances have a two piece top baffle.

- Close the door and slide the air control to the left.
- Once on the roof, remove the cowl from the top of flue system and sweep the flue pipe using a 150mm-diameter flue pipe brush as detailed in the instructions provided with the fluebrush.
- Once the flue pipe is clear, clean and refit the cowl. Remove the excess soot which has fallen into the firebox, leaving a layer of ash 10mm deep on the base of the firebox, then refit the top baffle.

Note: The baffle must be fitted so its rear is touching the back of the firebox; if uncertain refer to page 3 in the installation section at the front of this manual, which shows illustrations of the baffle location.

Wetback blanking plates

Metro Insert models can be fitted with a wetback and will feature wetback blanking plates in the side walls of the firebox. These plates 'seal' the wetback connection holes and are only removed if you choose to fit a wetback to your fire.

NO WETBACK FITTED

The wetback blanking plates should be checked annually, as any corrosion or deterioration can allow air to leak into the firebox at these points causing the appliance to 'over fire' and stress firebox integrity.

If deterioration is noticed during regular servicing and maintenance, please contact your Metro retailer or installer to have these blanking plates and sealing compound replaced. Failure to act on this may impact on warranty.

WETBACK FITTED

Wetback connection holes are sealed by your installer during wetback installation. The connection holes should be checked annually to ensure the seal remains intact, as any deterioration can allow air to leak into the firebox causing the appliance to 'over fire' and stress firebox integrity.

If deterioration is noticed during regular servicing and maintenance, please contact your Metro retailer or service agent. Failure to act on this may impact on warranty.

Troubleshooting your Metro fire

If your Metro is installed correctly, your fuel is dry and you operate your fire correctly, you will find it to be a pleasure to use. Metro's many years of experience within the wood heating industry has shown that dissatisfaction is mainly due to:

- unseasoned fuel
- faulty installation
- operational error
- or a combination of the above 3 points.

Correct operation

Modern day wood fires need to be operated hard and fast, more so than low and lazy to ensure the firebox and flue pipe runs hot and efficiently. If the fire and flue pipe is up to temperature it will perform extremely well, the smoke will draw up the flue pipe with ease, and the fire will produce good amounts of heat.

If the fire is operated on low a lot of the time, the door glass will run black, the flue pipe will tend to block up more frequently and the fire will end up smoking into the room when reloading. It's better to have a small fire running hard and fast, rather than a big fire running low and lazy.

The following may be of assistance if you are experiencing any problems with the operation of your Metro Fire.

Smoke enters the room when the Metro's door is ajar

(possible reasons and solutions)

Check flue pipe joins

If the flue pipe joins are not sealed correctly, the flue pipe will not draw as well as it should. The flue pipe join connecting into the flue spigot on top of the Metro is most critical, if this is not sealed correctly, smoke will enter the room when the door is ajar. To check this join is sealed correctly, run a match or lighter flame around the join. If the flame is sucked into the spigot then it is not sealed correctly. This check needs to be done when the fire is not going. Ensure you check the rear of the flue pipe/spigot join, as due to the seam in the flue pipe, this is the most common area for not being sealed correctly.

Ensure the fuel you are using is correctly seasoned

If you are burning unseasoned fuel (wet), the fire will cause nothing but problems. The Metro won't deliver much heat, it will be lazy, smoke will enter the room when the door is ajar, and the door glass will run black. Unseasoned fuel is the main contributor to excessive creosote deposits which can be corrosive to your appliance and flue system.

Flue pipe length is too short

Add more flue pipe as the longer the flue system, the better the draw of the flue pipe. Please note, if you did not purchase the Metro ECO Flue System, you will not have the ECO Cowl which increases draw. We highly recommend the Metro ECO Cowl is fitted as this will increase the draw. If you already have an ECO Cowl and smoke is still entering the room, please add another 600mm length of flue pipe.

Downdraft/Turbulence blockage

If you have checked all of the previous factors and the fire is still smoking into the room, it's possible there may be a down draft issue. Down draft is environmental and can be caused by many variables, and it is purely trial and error to ascertain the cause.

Air turbulence and/or negative air pressure influences around the flue termination can be caused by too close or overhanging trees or natural/artificial ridges etc. Address these where possible or look to extend the flue above the roofline.

Other options may be:

- 'H' Cowl, designed purely for downdraft issues, but if you have an ECO Cowl fitted as standard, you will also need to add another 600mm of flue pipe to compensate as the H Cowl is shorter in length
- Directional Cowl, designed for high wind areas.

Air control setting

Ensure the air control setting is on high before opening the door to reload, as this increases the draw up the flue pipe. Open the door slowly.

If your Metro did not smoke, but its starting too and is getting worse:

The flue pipe is in need of a clean. It is recommended that the flue pipe be cleaned every season, however if you are burning the fire on low a lot, or are using unseasoned fuel, flue pipe cleans will be required more frequently.

Other issues you may experience

I can smell smoke in the room after a low burn cycle

The smell is creosote that will be seeping through the flue pipe join or out of the flue spigot onto an external surface, thus creating the smell in your room. The cause will be either unseasoned fuel, fuel mass too large, incorrect operation on low burn cycles or a combination. Creosote is very corrosive and excessive buildups will result in the flue pipe and potentially the flue spigot and upper burn chamber failing. The formation of excessive creosote is not an appliance issue, it is a fuel and operational issue. Failure of flue pipe or firebox due to creosote build up is not covered under warranty as excessive creosote build up is only possible from either unseasoned fuel or incorrect operation.

The Metro won't turn down as much as it did

The door itself may need readjusting, the hinge and latch is slotted and allows for movement. Loosening the hinge and moving it back a few mm will make the door seal tighter and stop air leaking into the fire. The door and glass seals may be in need of replacing, which is generally required every 3-4 years.

Familiarise yourself with the instructions on page 11 before proceeding with this maintenance.

Warranty details for your Metro fire

Metro wood fires are manufactured in New Zealand, using the highest quality of materials, workmanship and the latest manufacturing techniques, which is why we offer a full 10 year firebox warranty and a 1 year parts warranty for your peace of mind.

Metro Warranty

(NZ Consumer laws apply to this warranty)

Pioneer Manufacturing Limited (Pioneer) warrants the steel firebox against defective materials and workmanship which would render it unfit for normal domestic use, from the date of purchase by the original consumer, for a period of 10 years.

Components including panel coating, door retainers, door seals, glass, trim, baffle & bricks are warranted for a period of 1 year from the date of original purchase for normal domestic use against defective materials and workmanship.

All associated accessories including, but not limited to, fans, flue systems, flue shields, wetbacks, tool sets, ash pots etc, are covered by a 1 year warranty against defective materials and workmanship.

It is recommended, but not a condition of this warranty, that a full service/inspection of the Metro fire be carried out at the end of each winter season.

Warranty Conditions

- The Metro fire must be installed, operated and maintained strictly in accordance with the building code and this installation and operation manual
- The Metro fire must be installed and used in a domestic application
- This warranty covers appliance like for like replacement or repair at the manufacturer's discretion but excludes freight, travel, installation, labour and/or any other associated costs
- Pioneer or their agents are not liable for any loss or expense direct or indirect arising from the failure of any part or operation of the appliance
- Operation of this appliance in violation of the warnings in this operation and installation manual will void this warranty
- Your Metro fire must be regularly maintained and we recommended it is also serviced annually. Proof of servicing may be required. If a wood fire is not regularly maintained and serviced, the life span will be reduced. If your Metro wood fire has been neglected, by not being regularly maintained and serviced, warranty may be declined

CAUTION! Important Information

Note: The following 3 points require regular inspection/maintenance (every time the ash bed is cleaned out, generally 3-5 times a season) and if not maintained will void the firebox warranty. Please ensure you keep your proof of purchase/receipt on any parts you buy.

- It is critical the fire not be operated with over worn, faulty or missing door seals. Door seals will harden over time and become over-worn (3-4 year's) and will cause air to leak into the fire, causing the appliance to 'over fire'. Do not operate the fire with cracked, or broken door glass
- It is critical the fire not be operated with over worn, faulty or missing bricks, baffle plate or baffle extension (white board on or under the baffle plate)
- A claim under this warranty should be directed to the retailer who supplied the Metro fire. If this is not possible write directly to the manufacturer stating details of fault, model, serial number of your Metro, dated proof of purchase and name of retailer purchased from.

Warranty Exclusions

(This manufacturer's warranty does not cover)

- Service calls which are not related to any defect in the product (i.e. operational, installation or fuel issues). The cost of a service call will be charged if the problem is not found to be a product fault
- Defects caused by factors other than normal domestic use or use in accordance with the product's operation manual
- Defects caused through the product being operated in an 'over-fired' manner resulting in sections of the firebox operating excessively hot to the point that sections glow red. (Note – This will result in distortion of the firebox)
- Defects to the product caused by accident, neglect, misuse or act of God
- The cost of repairs carried out by non-authorized repairers or the cost of correcting such unauthorised repairs
- Required maintenance as set out in this manual.

Service under this manufacturer's warranty must be provided by a repairer authorised by Pioneer Manufacturing Ltd. Such service shall be provided during normal business hours.

IMPORTANT! Complete and retain these details at time of purchase:

Purchase Date

Serial Number

Model

Colour

Retailer



Parts guide for your Metro – Promet, baffles and wetback options

Your Metro wood fire must be regularly maintained and we recommended it is also serviced annually. If a wood fire is not regularly maintained and serviced, the life span will be reduced.

If your Metro wood fire has been neglected, by not being regularly maintained and serviced, with authorised Metro parts replaced as required, your warranty may be declined.





Listed below are the parts and product codes for your Metro wood fire. The promet/baffle should be regularly checked and must always be in place during the operation of your fire.

The baffle should be resting on four support lugs (two on each side of the firebox). It must be hard back against the rear of the firebox with the 'promet extension' (white board) or return front steel edge of the baffle facing forward.

Hairline cracks in the promet extension are not uncommon and will have no adverse effect on the operation and performance of your Metro wood fire. These cracks are the result of intense heat coupled with expansion and contraction and is normal wear and tear.

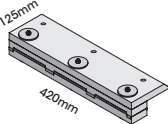
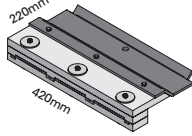
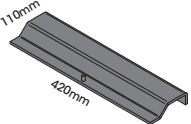
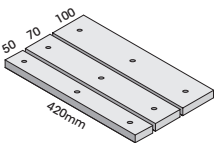
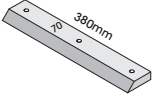
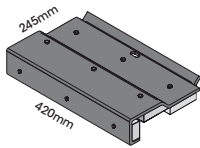
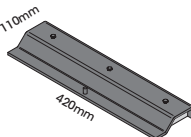
If the promet extension starts to break up and pieces fall into the firebox it must be replaced.

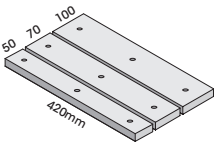
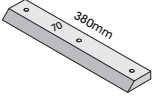
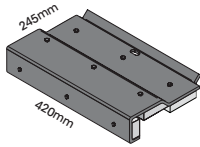
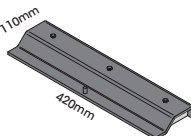
Note: Impact damage when loading wood and burning wood which is not properly seasoned, i.e. 25% moisture content or more, will cause the promet to disintegrate and require replacement. Always burn dry well seasoned wood and take care when loading wood into the firebox.

Model	Type of promet required / Type of steel baffle(s) required				Wetback options
• Trend Insert	ECO Small Promet 500-1650 	ECO Insert Front 500-2250 	ECO/LTD Insert Rear 500-2300 		No wetback if this fire is installed in a clean air zone. The 3kW or 4kW Wetback can be fitted in a non-clean air zone. 3kW Wetback 450-0100 or 4kW Wetback 450-0150
• Smart Insert	Smart Front Promet (2021) 500-1790 	Smart Rear Promet 500-1800 	Smart Front Baffle 500-2375 	Smart Rear Baffle 500-2400 	Smart Wetback 450-0350 
• LTD Smart Insert	Smart Front Promet (2021) 500-1790 	Smart Rear Promet 500-1800 	Smart Front Baffle 500-2375 	Smart Rear Baffle 500-2400 	Smart Wetback 450-0350 

Metro wood fire specifications

Metro have a Specifications Brochure available which details relevant compliance data for every model. This brochure is updated annually and details the minimum clearances and specifications for all models, which is generally required when applying for a building consent. See your Metro retailer to obtain a copy, or visit www.metrofires.co.nz

metrofires.co.nz

Visit the Metro website: metrofires.co.nz to view Metro's 'video demos' showing the latest in wood fire technology energy saving options. You can view the entire Metro product range, find out where your nearest Metro retailer is located or simply check out the latest specifications, installation requirements and emission and efficiency data for the Metro of your choice.



Pioneer heating accessories

Pioneer/Metro Fires offer a wide range of heating accessories designed to complement your Metro wood fire. The range includes ECO flue systems, floor protectors, wetbacks, heat transfer systems, baffles, bricks and more.

For further details talk to your Metro agency or visit www.metrofires.co.nz

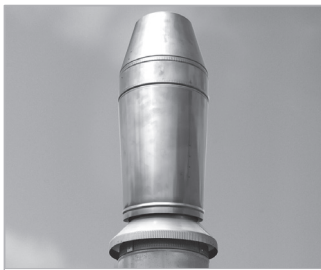

ECO Flue Systems

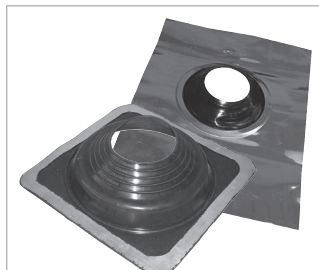

Flashrites and Versatiles



Wetbacks



High Temperature Paint



Corner and Wall Floor Protectors



Heat Transfer Systems



Universal Door Seal Kits



Fire Cement And Silicone



Glass Tape



Door Seal Rope



Smoke Detectors