

# Mega Smart Built-In

The perfect blend of functionality and smart contemporary styling. The Mega Smart is a dedicated 'Built-In' appliance designed for installation into a timber framed cavity. With an outstanding peak heat output of 18kW and wetback capable, the Mega Smart Built-In is designed for heating large open areas and will drive out the cold all winter long. Fascia finished in metallic black high temperature paint.

<b>Model</b>	Clean air approved
<b>Peak output</b>	18kW
<b>Heating area</b>	200m <sup>2</sup> / 4 bedroom home
<b>Finish</b>	Metallic black paint
<b>Wetback</b>	Mega Smart Booster
<b>MfE#</b>	110719 (DRY) / 111058 (WET)
<b>Emission</b>	0.65gms (DRY) / 0.56gms (WET)
<b>Efficiency</b>	69% (DRY) / 66% (WET)
<b>SKU</b>	250-0867



**ECO FLUE**

Maximise the performance and efficiency of your wood fire

## SPECIFICATIONS

A	B	C	D	E	F	G	H	I	J	K	L
860	631	814	445	1057	30	822	1057	505	212	402	500
Fascia dimensions (mm)					Width	Depth	Height				
					1057	30	822				

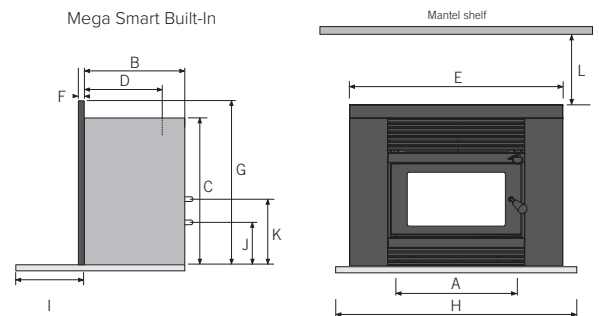

Please note: All measurements detailed above are in (mm). Specifications were correct at the time of printing but may alter and those detailed should be used only as a guide. If in doubt, please consult your local Metro Fires agency or visit [metrofires.co.nz](http://metrofires.co.nz).

METROFIRES.CO.NZ

**metrofires**